

Content

Monitoring relay industrial design

1-phase current monitoring relay	6.2
1-phase voltage monitoring relay	6.6
3-phase voltage monitoring relay	6.10
3-phase voltage monitoring relay (Multifunction)	6.14
Temperature monitoring relay	6.18
Load monitoring	6.22
Accessories	6.26
Protection cover	6.26
Mounting plate	6.26
Technical safety advice	6.27
Prescriptions and standards	6.28

1-phase current monitoring relay

EMR DI22F



EMR DI22F

- **AC/DC current monitoring in 1-phase mains**
- **Measuring range 100 mA / 1A / 10A ac/dc**
- **Multifunction**
- **16,6 ... 400 Hz**
- **Error Memory (Latch)**
- **2 change-over contacts**

Functions

ac/dc current monitoring in 1-phase mains with adjustable thresholds, timing for start-up suppression and tripping delay separately adjustable and the following functions (selectable by means of rotary switch)

- Overcurrent monitoring
- Overcurrent monitoring with error memory
- Undercurrent monitoring
- Undercurrent monitoring with error memory
- Monitoring the window between Min and Max
- Monitoring the window between Min and Max with error memory

Time ranges

Start-up suppression time: Adjustment range 0 ... 10 s

Tripping delay: Adjustment range 0.1 ... 10 s

Indicators

Green LED ON: indication of supply voltage

Green LED flashing: indication of start-up suppression time

Yellow LED ON/OFF: indication of relay output

Red LED ON/OFF: indication of failure of the corresponding threshold

Red LED flashing: indication of tripping delay of the corresponding threshold

Output relay

2 potential free change-over contacts

Rated voltage: 250 Vac

Switching capacity (distance <5 mm): 750 VA (3 A / 250 Vac)

Switching capacity (distance >5 mm): 1250 VA (5 A / 250 Vac)

Fusing: 5A fast acting

Connecting voltages

24 ... 240 Vdc, -20% ... +25% (galvanically separated)

24 ... 240 Vac, -15% ... +10% (galvanically separated)

100% duration of operation

Reference data

Selectron® EMR	Article no.
EMR DI22F 24 ... 240 Vac/dc	41230005
(Order data see chapter 1)	

1-phase current monitoring relay

EMR DI22F

Technical data	
Nominal consumption	4.5 VA / 1 W
Nominal frequency	48 ... 400 Hz (24 ... 240 Vac)
	16 ... 48 Hz (48 ... 240 Vac)
Wave form for ac	sine
Ripple at dc	10%
Drop-out voltage	>15% of the supply voltage
Base accuracy	±5% (of maximum scale value)
Adjustment accuracy	≤5% (of maximum scale value)
Repetition accuracy	≤2%
Temperature influence	≤0.1% / °C
Frequency response	-10% ... +5% (16.6 ... 400 Hz)
Recovery time	500 ms
Measuring circuit: Input:	
100 mA ac/dc	terminals K and I1(+)
1 A ac/dc	terminals K and I2(+)
10 A ac/dc	terminals K and I3(+) (distance >5 mm)
Overload capacity:	
100 mA ac/dc	800 mA
1 A ac/dc	3 A
10 A ac/dc	12 A
Input resistance:	
100 mA ac/dc	470 mΩ
1 A ac/dc	47 mΩ
10 A ac/dc	5 mΩ
Switching threshold:	
Max:	10% ... 100% of I_N
Min:	5% ... 95% of I_N

Type key

EMR D I 2 2 F ...	
Construction	Special functions
D Industrial design 22.5 mm	1 = Additional asymmetry monitoring
S pluggable 11 poles	
Function	Measuring circuit
U Voltage	A No measuring circuit
I Current	B 3(N)~115/66 Vac
P CosPhi	C 3(N)~230/132 Vac
T Temperature	D 3(N)~400/230 Vac
S Star-Delta	E 1 ≅ 30/60/300 Vac/dc
	F 1 ≅ 100mA/1A/10A ac/dc
	G PTC
	H CosPhi
Output	Connecting voltage
1 1 changer	1 Measuring circuit
2 2 changers	2 24...240 Vac/dc
3 1 NC contact / 1 NO contact	3 230 Vac
	I 12 Vdc
	J 24 Vdc
	K 36 Vdc
	L 48 Vdc
	M 1~110 Vac
	N 1~230 Vac
	O 1 A
	P 5 A

1-phase current monitoring relay

EMR DI22F

Function description

When the supply voltage U is applied, the output relays switch into on-position (yellow LED illuminated) and the set interval of the start-up suppression (START) begins (green LED U flashes). Changes of the measured current during this period do not affect the state of the output relay. After the interval has expired the green LED is illuminated steadily.

For all the functions the LEDs MIN and MAX are flashing alternating, when the minimum value for the measured current was chosen to be greater than the maximum value.

Overcurrent monitoring (OVER, OVER+LATCH)

When the measured current exceeds the value adjusted at the MAX-regulator, the set interval of the tripping delay (DELAY) begins (red LED MAX flashes). After the interval has expired (red LED MAX illuminated), the output relays switch into off-position (yellow LED not illuminated). The output relays again switch into on-position (yellow LED illuminated), when the measured current falls below the value adjusted at the MIN-regulator (red LED MAX not illuminated).

If the error memory is activated (OVER+LATCH) and the measured current remains above the MAX-value longer than the set interval of the tripping delay, the output relays remain in the off-position even if the measured current falls below the value adjusted at the MIN-regulator. After resetting the failure (interrupting and re-applying the supply voltage), the output relays switch into on-position and a new measuring cycle begins with the set interval of the start-up suppression (START).

Undercurrent monitoring (UNDER, UNDER+LATCH)

When the measured current falls below the value adjusted at the MIN-regulator, the set interval of the tripping delay (DELAY) begins (red LED MIN flashes). After the interval has expired (red LED MIN illuminated), the output relays switch into off-position (yellow LED not illuminated). The output relays again switch into on-position (yellow LED illuminated), when the measured current exceeds the value adjusted at the MAX-regulator.

If the error memory is activated (UNDER+LATCH) and the measured current remains below the MIN-value longer than the set interval of the tripping delay, the output relays remain in the off-position even if the measured current exceeds the value adjusted at the MAX-regulator. After resetting the failure (interrupting and re-applying the supply voltage), the output relays switch into on-position and a new measuring cycle begins with the set interval of the start-up suppression (START).

Window function (WIN, WIN+LATCH)

The output relays switch into on-position (yellow LED illuminated) when the measured current exceeds the value adjusted at the MIN-regulator. When the measured current exceeds the value adjusted at the MAX-regulator, the set interval of the tripping delay (DELAY) begins (red LED MAX flashes). After the interval has expired (red LED MAX illuminated), the output relays switch into off-position (yellow LED not illuminated). The output relays again switch into on-position (yellow LED illuminated) when the measured current falls below the value adjusted at the MAX-regulator (red LED MAX not illuminated). When the measured current falls below the value

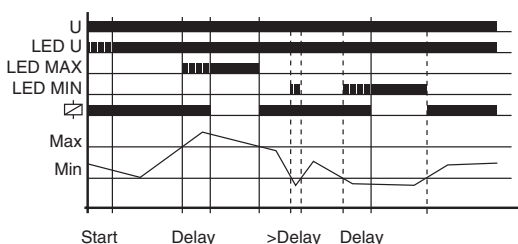
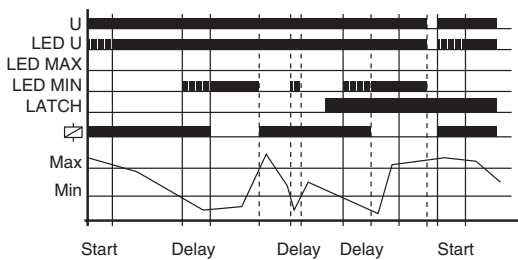
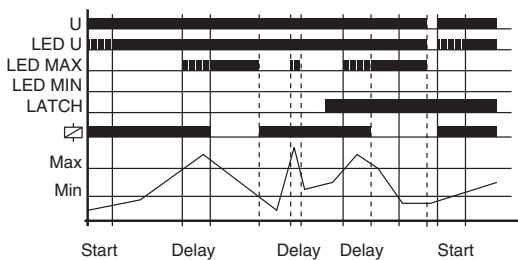

1-phase current monitoring relay

EMR DI22F

adjusted at the MIN-regulator, the set interval of the tripping delay (DELAY) begins again (red LED MIN flashes). After the interval has expired (red LED MIN illuminated), the output relays switch into off-position (yellow LED not illuminated).

If the error memory is activated (WIN+LATCH) and the measured current remains below the MIN-value longer than the set interval of the tripping delay, the output relays remain in the off-position even if the measured current exceeds the value adjusted at the MIN-regulator. If the measured current remains above the MAX-value longer than the set interval of the tripping delay, the output relays remain in the off-position even if the measured current falls below the value adjusted at the MAX-regulator. After resetting the failure (interrupting and re-applying the supply voltage), the output relays switch into on-position and a new measuring cycle begins with the set interval of the start-up suppression (START).

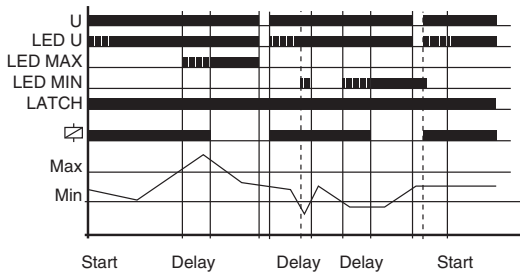

Connection

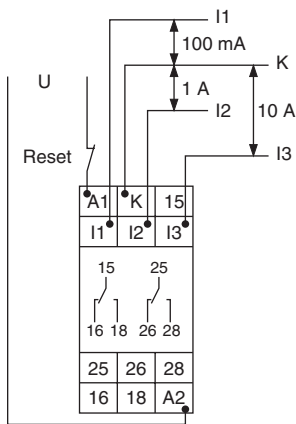

With error memory
Measuring range 100 mA, 1 A or 10 A
U = supply voltage 24 ... 240 Vac/dc

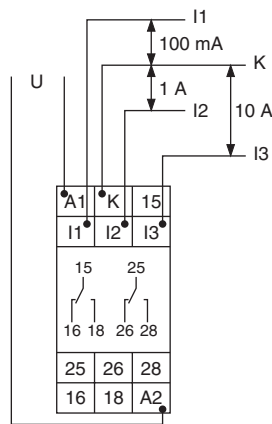

Without error memory
Measuring range 100 mA, 1 A or 10 A
U = supply voltage 24 ... 240 Vac/dc

Dimensions

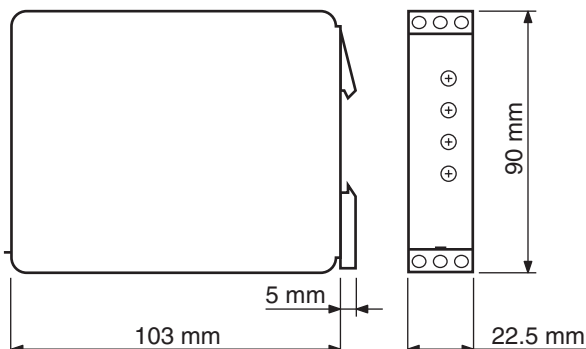

1-phase voltage monitoring relay

EMR DU22E



EMR DU22E

- ac/dc voltage monitoring in 1-phase mains
- Measuring range 30/60/300 Vac/dc
- Multifunction
- 16,6 ... 400 Hz
- Error Memory (Latch)
- 2 change-over contacts

Functions

ac/dc voltage monitoring in 1-phase mains with adjustable thresholds, timing for start-up suppression and tripping delay separately adjustable and the following functions (selectable by means of rotary switch)

- Overvoltage monitoring
- Overvoltage monitoring with error memory
- Undervoltage monitoring
- Undervoltage monitoring with error memory
- Monitoring the window between Min and Max
- Monitoring the window between Min and Max with error memory

Time ranges

Start-up suppression time: Adjustment range 0 ... 10 s

Tripping delay: Adjustment range 0.1 ... 10 s

Indicators

- Green LED ON: indication of supply voltage
- Green LED flashing: indication of start-up suppression time
- Yellow LED ON/OFF: indication of relay output
- Red LED ON/OFF: indication of failure of the corresponding threshold
- Red LED flashing: indication of tripping delay of the corresponding threshold

Output relay

2 potential free change-over contacts

Rated voltage: 250 Vac

Switching capacity (distance <5 mm): 750 VA (3 A / 250 Vac)

Switching capacity (distance >5 mm): 1250 VA (5 A / 250 Vac)

Fusing: 5A fast acting

Connecting voltages

24 ... 240 Vdc, -20% ... +25% (galvanically separated)

24 ... 240 Vac, -15% ... +10% (galvanically separated)

100% duration of operation

Reference data

Selectron® EMR	Article no.
DU22E 24 ... 240 Vac/dc	41230004
(Order data see chapter 1)	

1-phase voltage monitoring relay

EMR DU22E

Technical data		
Nominal consumption		4.5 VA / 1 W
Nominal frequency		48 ... 400 Hz (24 ... 240 Vac)
		16 ... 48 Hz (48 ... 240 Vac)
Wave form for ac		sine
Ripple at dc		10%
Drop-out voltage		>15% of the supply voltage
Base accuracy		±5% (of maximum scale value)
Adjustment accuracy		≤5% (of maximum scale value)
Repetition accuracy		≤2%
Temperature influence		≤0.1% / °C
Frequency response		-10% ... +5% (16.6 ... 400 Hz)
Voltage influence		≤0.5%
Recovery time		500 ms
Measuring circuit:	Fusing	max. 20 A (according to UL 508)
	Measured variable	dc or ac sine (16.6 ... 400 Hz)
	Input:	
	30 Vac/dc	terminals E and F1(+)
	60 Vac/dc	terminals E and F2(+)
	300 Vac/dc	terminals E and F3(+)
	Overload capacity:	
	30 Vac/dc	100 V _{eff}
	60 Vac/dc	150 V _{eff}
	300 Vac/dc	440 V _{eff}
	Input resistance:	
	30 Vac/dc	47 kΩ
	60 Vac/dc	100 kΩ
	300 Vac/dc	470 kΩ
	Switching threshold:	
	Max:	10% ... 100% von U _N
	Min:	5% ... 95% von U _N

Type key

EMR D U 2 2 E ...	
Construction	Special functions
D Industrial design 22.5 mm	1 = Additional asymmetry monitoring
S pluggable 11 poles	
Function	Measuring circuit
U Voltage	A No measuring circuit
I Current	B 3(N)~115/66 Vac
P CosPhi	C 3(N)~230/132 Vac
T Temperature	D 3(N)~400/230 Vac
S Star-Delta	E 1 ≅ 30/60/300 Vac/dc
	F 1 ≅ 100mA/1A/10A ac/dc
	G PTC
	H CosPhi
	I 12 Vdc
	J 24 Vdc
	K 36 Vdc
	L 48 Vdc
	M 1~110 Vac
	N 1~230 Vac
	O 1 A
	P 5 A
Output	Connecting voltage
1 1 changer	1 Measuring circuit
2 2 changers	2 24...240 Vac/dc
3 1 NC contact / 1 NO contact	3 230 Vac

1-phase voltage monitoring relay

EMR DU22E

Function description

When the supply voltage U is applied, the output relays switch into on-position (yellow LED illuminated) and the set interval of the start-up suppression (START) begins (green LED U flashes). Changes of the measured voltage during this period do not affect the state of the output relay. After the interval has expired the green LED is illuminated steadily.

For all the functions the LEDs MIN and MAX are flashing alternating, when the minimum value for the measured voltage was chosen to be greater than the maximum value.

Overvoltage monitoring (OVER, OVER+LATCH)

When the measured voltage exceeds the value adjusted at the MAX-regulator, the set interval of the tripping delay (DELAY) begins (red LED MAX flashes). After the interval has expired (red LED MAX illuminated), the output relays switch into off-position (yellow LED not illuminated). The output relays again switch into on-position (yellow LED illuminated), when the measured voltage falls below the value adjusted at the MIN-regulator (red LED MAX not illuminated).

If the error memory is activated (OVER+LATCH) and the measured voltage remains above the MAX-value longer than the set interval of the tripping delay, the output relays remain in the off-position even if the measured voltage falls below the value adjusted at the MIN-regulator. After resetting the failure (interrupting and re-applying the supply voltage), the output relays switch into on-position and a new measuring cycle begins with the set interval of the start-up suppression (START).

Undervoltage monitoring (UNDER, UNDER+LATCH)

When the measured voltage falls below the value adjusted at the MIN-regulator, the set interval of the tripping delay (DELAY) begins (red LED MIN flashes). After the interval has expired (red LED MIN illuminated), the output relays switch into off-position (yellow LED not illuminated). The output relays again switch into on-position (yellow LED illuminated), when the measured voltage exceeds the value adjusted at the MAX-regulator.

If the error memory is activated (UNDER+LATCH) and the measured voltage remains below the MIN-value longer than the set interval of the tripping delay, the output relays remain in the off-position even if the measured voltage exceeds the value adjusted at the MAX-regulator. After resetting the failure (interrupting and re-applying the supply voltage), the output relays switch into on-position and a new measuring cycle begins with the set interval of the start-up suppression (START).

Window function (WIN, WIN+LATCH)

The output relays switch into on-position (yellow LED illuminated) when the measured voltage exceeds the value adjusted at the MIN-regulator. When the measured voltage exceeds the value adjusted at the MAX-regulator, the set interval of the tripping delay (DELAY) begins (red LED MAX flashes). After the interval has expired (red LED MAX illuminated), the output relays switch into off-position (yellow LED not illuminated). The output relays again switch into on-position (yellow LED illuminated) when the measured voltage falls below the value adjusted at the MAX-regulator (red LED MAX not illuminated). When the measured voltage falls below the value

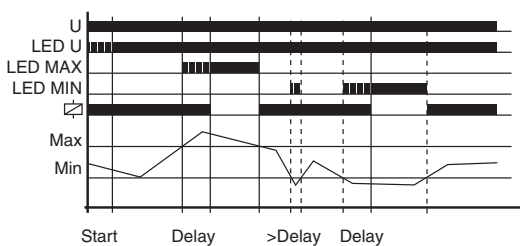
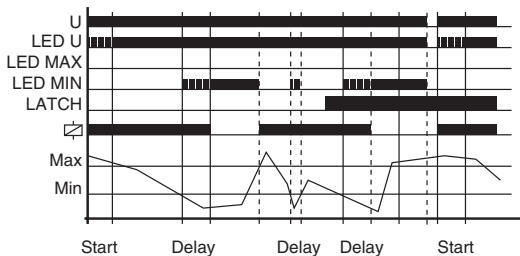
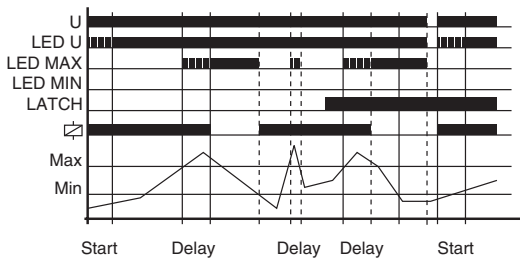

1-phase voltage monitoring relay

EMR DU22E

adjusted at the MIN-regulator, the set interval of the tripping delay (DELAY) begins again (red LED MIN flashes). After the interval has expired (red LED MIN illuminated), the output relays switch into off-position (yellow LED not illuminated).

If the error memory is activated (WIN+LATCH) and the measured voltage remains below the MIN-value longer than the set interval of the tripping delay, the output relays remain in the off-position even if the measured voltage exceeds the value adjusted at the MIN-regulator. If the measured voltage remains above the MAX-value longer than the set interval of the tripping delay, the output relays remain in the off-position even if the measured voltage falls below the value adjusted at the MAX-regulator. After resetting the failure (interrupting and re-applying the supply voltage), the output relays switch into on-position and a new measuring cycle begins with the set interval of the start-up suppression (START).

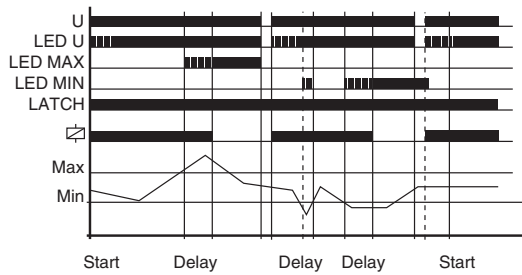

Connection

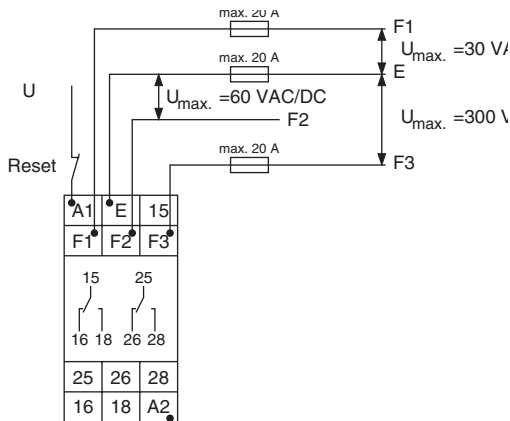

With error memory
 Measuring range U_{max} 30, 60 or 300 Vac/dc
 U = supply voltage 24 ... 240 Vac/dc

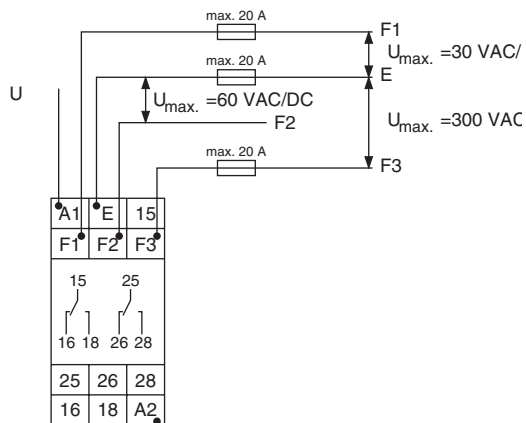

Without error memory
 Measuring range U_{max} 30, 60 or 300 Vac/dc
 U = supply voltage 24 ... 240 Vac/dc

Dimensions

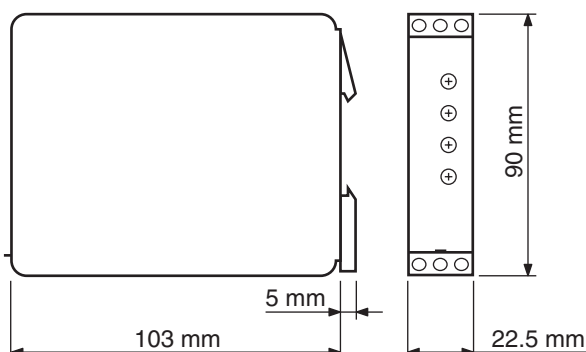

3-phase voltage monitoring relay

EMR DU21D



EMR DU21D

- **Voltage monitoring in 3-phase mains**
- **Measuring range 230 ... 400 Vac 3Ph**
- **Monitoring of phase sequence and phase failure**
- **Detection of reverse voltage**
- **Connection of neutral wire optional**
- **2 changers**

Functions

Monitoring of phase sequence, phase failure and detection of return voltage (by means of evaluating the asymmetry).

Time ranges

Start-up suppression time: max. 500 ms

Tripping delay: max. 350 ms

Indicators

Green LED ON: indication of supply voltage

Yellow LED ON/OFF: indication of relay output

Output relay

2 potential free change-over contacts

Rated voltage: 250 Vac

Switching capacity (distance <5 mm): 750 VA (3 A / 250 Vac)

Switching capacity (distance >5 mm): 1250 VA (5 A / 250 Vac)

Fusing: 5A fast acting

Connecting voltages

3(N) ~230/400 V, Terminals (N)-L1-L2-L3 (= supply voltage)

Tolerance: 3(N) ~230/400 V, 3(N) ~342 ... 457 V

Reference data

Selectron® EMR	Article no.
DU21D 230 ... 400 Vac 3Ph	41230001
(Order data see chapter 1)	

3-phase voltage monitoring relay

EMR DU21D

Technical data	
Nominal consumption	3(N) ~230/400 V, 9 VA
Nominal frequency	48 ... 63 Hz
Drop-out voltage	>20% of the supply voltage
Recovery time	500 ms
Measuring circuit: Input:	
	3(N) ~230/400 V Terminals (N)-L1-L2-L3 (= supply voltage)
Overload capacity:	
	3(N) ~230/400 V 3(N) ~264/457 V
Input resistance:	
	3(N) ~230/400 V 15 kΩ
Asymmetry:	typ. 30%

Type key

EMR D U 2 1 D ...	
Construction	Special functions
D Industrial design 22.5 mm	1 = Additional asymmetry monitoring
S pluggable 11 poles	
Function	Measuring circuit
U Voltage	A No measuring circuit
I Current	B 3(N)~115/66 Vac
P CosPhi	C 3(N)~230/132 Vac
T Temperature	D 3(N)~400/230 Vac
S Star-Delta	E 1 ≅ 30/60/300 Vac/dc
	F 1 ≅ 100mA/1A/10A ac/dc
	G PTC
	H CosPhi
	I 12 Vdc
	J 24 Vdc
	K 36 Vdc
	L 48 Vdc
	M 1~110 Vac
	N 1~230 Vac
	O 1 A
	P 5 A
Output	Connecting voltage
1 1 changer	1 Measuring circuit
2 2 changers	2 24...240 Vac/dc
3 1 NC contact / 1 NO contact	3 230 Vac

3-phase voltage monitoring relay

EMR DU21D

Function description

Phase sequence monitoring

When all the phases are connected in the correct sequence and the measured asymmetry is less than the fixed value, the output relays switch into on-position (yellow LED illuminated). When the phase sequence changes, the output relays switch into off-position (yellow LED not illuminated).

Phase failure monitoring

When one of the three phases fails, the output relays switch into off-position (yellow LED not illuminated).

Detection of reverse voltage (by means of evaluation of asymmetry)

The output relays switch into off-position (yellow LED not illuminated) when the asymmetry between the phase voltages exceeds the fixed value of the asymmetry.

An asymmetry caused by the reverse voltage of a consumer (e.g. a motor which continues to run on two phases only) does not effect the disconnection.

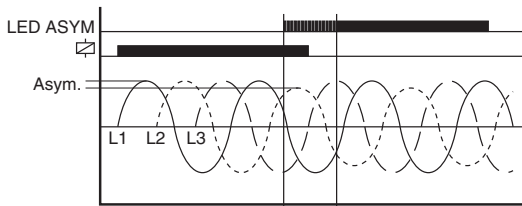
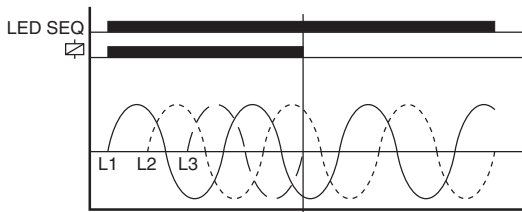
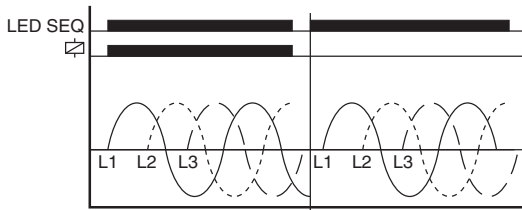

Connection

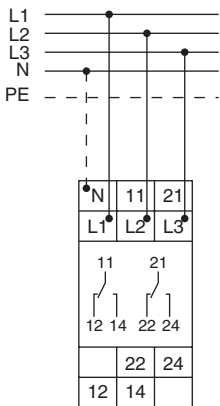

Dimensions

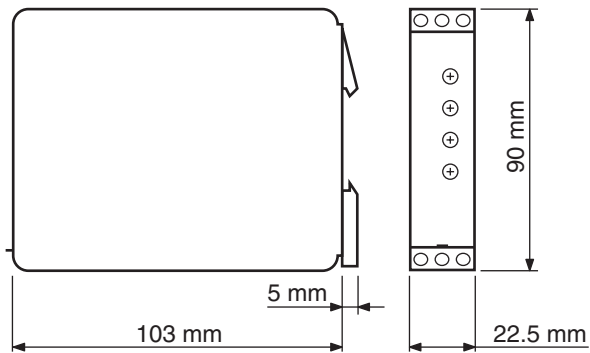

3-phase voltage monitoring relay (Multifunction)

EMR DU21C1, EMR DU21D1



EMR DU21C1



EMR DU21D1

- Voltage monitoring in 3-phase mains
- Measuring range 132...230 / 230...400 Vac 3Ph
- Multifunction
- Monitoring of phase sequence and phase failure
- Additional asymmetry monitoring
- Connection of neutral wire optional
- 2 changers

Functions

Voltage monitoring in 3-phase mains with adjustable thresholds, adjustable tripping delay, monitoring of phase sequence and phase failure, monitoring of asymmetry with adjustable threshold and the following functions (selectable by means of rotary switch)

- Undervoltage monitoring
- Undervoltage monitoring and monitoring of phase sequence
- Monitoring of window between Min and Max
- Monitoring the window between Min and Max and monitoring of phase sequence.

Time ranges

Start-up suppression time: -
 Tripping delay: Adjustment range 0.1 ... 10 s

Indicators

Red LED ON/OFF: indication of failure of the corresponding threshold
 Red LED flashes: indication of tripping delay of the corresponding threshold
 Yellow LED ON/OFF: indication of relay output

Output relay

2 potential free change-over contacts
 Rated voltage: 250 Vac
 Switching capacity (distance <5 mm): 750 VA (3 A / 250 Vac)
 Switching capacity (distance >5 mm): 1250 VA (5 A / 250 Vac)
 Fusing: 5A fast acting

Connecting voltages

24 ... 240 Vac/dc, Terminals A1-A2 (galvanically separated)
 Tolerance: 24 ... 240 Vdc, -20% ... +25% (galvanically separated)
 24 ... 240 Vac, -15% ... +10% (galvanically separated)
 100% duration of operation

Reference data

Selectron® EMR	Article no.
DU21D1 230 ... 400 Vac 3Ph	41230002
DU21C1 132 ... 230 Vac 3Ph	41230003
(Order data see chapter 1)	

3-phase voltage monitoring relay (Multifunction)

EMR DU21C1, EMR DU21D1

Technical data	
Nominal consumption	3(N) ~132/230 V, 4,5 VA (1 W) 3(N) ~230/400 V, 4,5 VA (1 W)
Nominal frequency	48 ... 400 Hz (24 ... 240 Vac) 16 ... 48 Hz (48 ... 240 Vac)
Wave form for ac	sine
Ripple at dc	10%
Drop-out voltage	>15% of the supply voltage
Base accuracy	±5% (of maximum scale value)
Adjustment accuracy	≤5% (of maximum scale value)
Repetition accuracy	≤2%
Temperature influence	≤0.1% / °C
Recovery time	500 ms
Measuring circuit:	Fusing: max. 20 A (according to UL 508)
	Measured variable: ac sine (48 ... 63 Hz)
	Input:
	3(N) ~132/230 V Terminals (N)-L1-L2-L3
	3(N) ~230/400 V Terminals (N)-L1-L2-L3
	Overload capacity:
	3(N) ~132/230 V 3(N) ~199/345 V
	3(N) ~230/400 V 3(N) ~346/600 V
	Input resistance:
	3(N) ~132/230 V 470 kΩ
	3(N) ~230/400 V 1 MΩ
	Switching threshold:
	Max: -20% ... +30% von U _N
	Min: -30% ... +20% von U _N
	Asymmetry: 5% ... 25%

Type key

EMR D U 2 1 C 1																	
<p>Construction</p> <p>D Industrial design 22.5 mm S pluggable 11 poles</p> <p>Function</p> <p>U Voltage I Current P CosPhi T Temperature S Star-Delta</p> <p>Output</p> <p>1 1 changer 2 2 changers 3 1 NC contact / 1 NO contact</p>	<p>Special functions</p> <p>1 = Additional asymmetry monitoring</p> <p>Measuring circuit</p> <table border="0"> <tr> <td>A No measuring circuit</td> <td>I 12 Vdc</td> </tr> <tr> <td>B 3(N)~115/66 Vac</td> <td>J 24 Vdc</td> </tr> <tr> <td>C 3(N)~230/132 Vac</td> <td>K 36 Vdc</td> </tr> <tr> <td>D 3(N)~400/230 Vac</td> <td>L 48 Vdc</td> </tr> <tr> <td>E 1≅ 30/60/300 Vac/dc</td> <td>M 1~110 Vac</td> </tr> <tr> <td>F 1≅ 100mA/1A/10A ac/dc</td> <td>N 1~230 Vac</td> </tr> <tr> <td>G PTC</td> <td>O 1 A</td> </tr> <tr> <td>H CosPhi</td> <td>P 5 A</td> </tr> </table> <p>Connecting voltage</p> <p>1 Measuring circuit 2 24...240 Vac/dc 3 230 Vac</p>	A No measuring circuit	I 12 Vdc	B 3(N)~115/66 Vac	J 24 Vdc	C 3(N)~230/132 Vac	K 36 Vdc	D 3(N)~400/230 Vac	L 48 Vdc	E 1≅ 30/60/300 Vac/dc	M 1~110 Vac	F 1≅ 100mA/1A/10A ac/dc	N 1~230 Vac	G PTC	O 1 A	H CosPhi	P 5 A
A No measuring circuit	I 12 Vdc																
B 3(N)~115/66 Vac	J 24 Vdc																
C 3(N)~230/132 Vac	K 36 Vdc																
D 3(N)~400/230 Vac	L 48 Vdc																
E 1≅ 30/60/300 Vac/dc	M 1~110 Vac																
F 1≅ 100mA/1A/10A ac/dc	N 1~230 Vac																
G PTC	O 1 A																
H CosPhi	P 5 A																

3-phase voltage monitoring relay (Multifunction)

EMR DU21C1, EMR DU21D1

Function description

For all the functions the LEDs MIN and MAX are flashing alternating, when the minimum value for the measured voltage was chosen to be greater than the maximum value.

If a failure already exists when the device is activated, the output relays remain in off-position and the LED for the corresponding threshold is illuminated.

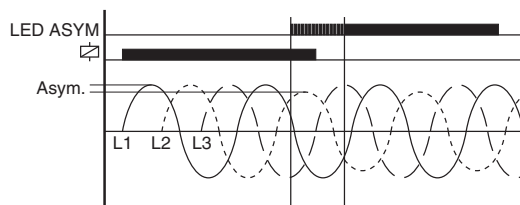
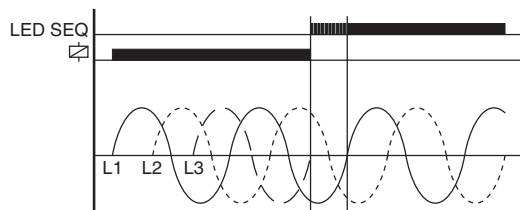
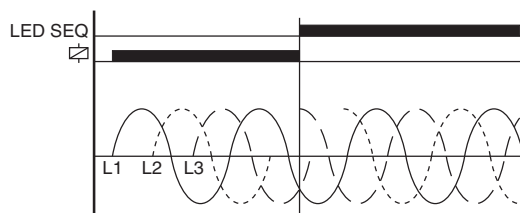
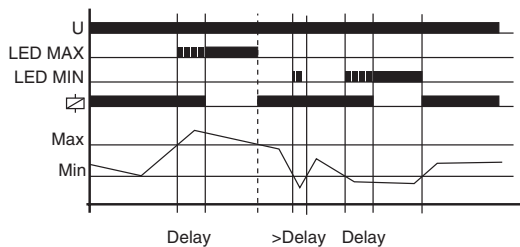
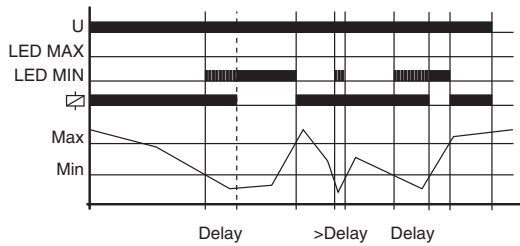

Under voltage monitoring (UNDER, UNDER+SEQ)

When the measured voltage (mean value of phase-to-phase voltages) falls below the value adjusted at the MIN-regulator, the set interval of the tripping delay (DELAY) begins (red LED MIN flashes). After the interval has expired (red LED MIN illuminated), the output relays switch into off-position (yellow LED not illuminated). The output relays again switch into on-position (yellow LED illuminated), when the measured voltage exceeds the value adjusted at the MAX-regulator.

Window function (WIN, WIN+SEQ)

The output relays switch into on-position (yellow LED illuminated) when the measured voltage (mean value of phase-to-phase voltages) exceeds the value adjusted at the MIN-regulator. When the measured voltage exceeds the value adjusted at the MAX-regulator, the set interval of the tripping delay (DELAY) begins (red LED MAX flashes). After the interval has expired (red LED MAX illuminated), the output relays switch into off-position (yellow LED not illuminated). The output relays again switch into on-position (yellow LED illuminated) when the measured voltage falls below the value adjusted at the MAX-regulator (red LED MAX not illuminated). When the measured voltage falls below the value adjusted at the MIN-regulator, the set interval of the tripping delay (DELAY) begins again (red LED MIN flashes). After the interval has expired (red LED MIN illuminated), the output relays switch into off-position (yellow LED not illuminated).

Phase sequence monitoring (SEQ)

Phase sequence monitoring is selectable for all functions.

If a change in phase sequence is detected (red LED SEQ illuminated), the output relays switch into off-position immediately (yellow LED not illuminated).

Phase failure monitoring (SEQ)

If one of the phase voltages fails, the set interval of the tripping delay (DELAY) begins (red LED SEQ flashes). After the interval has expired (red LED SEQ illuminated), the output relays switch into off-position (yellow LED not illuminated).

Reverse voltages of a consumer (e.g. a motor which continues to run on two phases only) do not effect the disconnection but can be monitored by using a proper value for the asymmetry.

Asymmetry monitoring

If the asymmetry of the phase-to-phase voltages exceeds the value set at the ASYM-regulator, the set interval of the tripping delay (DELAY) begins (red LED ASYM flashes). After the interval has expired (red LED ASYM illuminated), the output relays switch into off-position (yellow LED not illuminated).

3-phase voltage monitoring relay (Multifunction)

EMR DU21C1, EMR DU21D1

If the neutral wire is connected to the device, the asymmetry of the phase voltages referred to the neutral wire (Y-voltage) is monitored also. In that case both values of the asymmetry are evaluated and if one of the values exceeds the value set at the ASYM-regulator, the set interval of the tripping delay (DELAY) begins (red LED ASYM flashes). After the interval has expired (red LED ASYM illuminated), the output relays switch into off-position (yellow LED not illuminated).

Loss of neutral wire by means of evaluation of asymmetry

A break of the neutral wire between power line and machinery is detected as soon as asymmetry between phase-to-phase voltage and neutral wire occurs. If the asymmetry exceeds the value set at the ASYM-regulator, the set interval of the tripping delay (DELAY) begins (red LED ASYM flashes). After the interval has expired (red LED ASYM illuminated), the output relays switch into off-position (yellow LED not illuminated). A break of the neutral wire between our device and the machinery can not be detected.

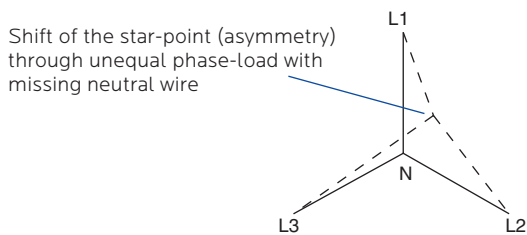

Connection

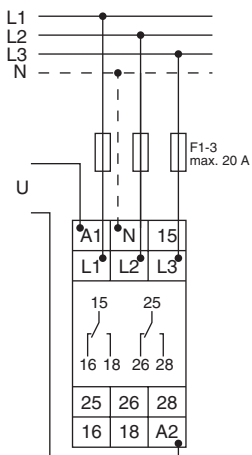

Supply voltage 24 ... 240 Vac/dc

Dimensions

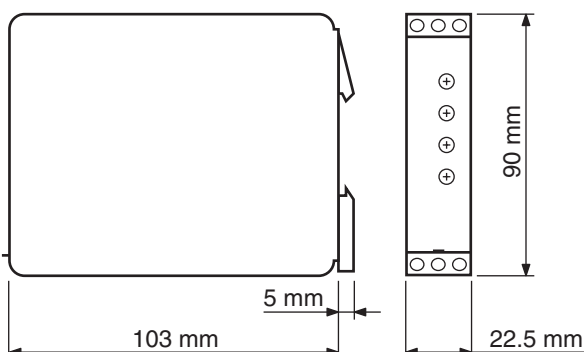

Temperature monitoring relay

EMR DT22G



EMR DT22G

- Temperature monitoring of the motor winding
- 2 changers
- External reset key connectable

Functions

Temperature monitoring of the motor winding (max. 6 PTC) with fault latch, for temperature probes in accordance with DIN 44081. Test function with integrated test/reset key.

Indicators

Green LED ON: indication of supply voltage
Red LED ON/OFF: indication of failure

Output relay

2 potential free change-over contacts
Rated voltage: 250 Vac
Switching capacity (distance <5 mm): 750 VA (3 A / 250 Vac)
Switching capacity (distance >5 mm): 1250 VA (5 A / 250 Vac)
Fusing: 5A fast acting

Connecting voltages

24 ... 240 Vac/dc, Terminals A1-A2 (galvanically separated)
Tolerance: 24 ... 240 Vdc, -20% ... +25% (galvanically separated)
24 ... 240 Vac, -15% ... +10% (galvanically separated)
100% duration of operation

Reference data

Selectron® EMR	Article no.
DT22G 24 ... 240 Vac/dc	41230006
(Order data see chapter 1)	

Temperature monitoring relay

EMR DT22G

Technical data	
Nominal consumption	4.5 VA / 1 W
Nominal frequency	48 ... 400 Hz (24 ... 240 Vac)
	16 ... 48 Hz (48 ... 240 Vac)
Wave form for ac	sine
Ripple at dc	10%
Drop-out voltage	>15% of the supply voltage
Base accuracy	±10% (of maximum scale value)
Repetition accuracy	≤1%
Temperature influence	≤0.1% / °C
Recovery time	500 ms
Measuring circuit:	Terminals T1-T2
Initial resistance	<1.5 kΩ
Response value (relay in off-position)	≥3.6 kΩ
Release value (relay in on-position)	≤1.8 kΩ
Disconnection (short circuit thermistor)	No
Measuring voltage T1-T2	≤2.5 Vdc at R ≤4.0 kΩ
	(according to DIN VDE 0660 Teil 302)

Type key

EMR D T 2 2 G ...																	
<p>Construction</p> <p>D Industrial design 22.5 mm S pluggable 11 poles</p> <p>Function</p> <p>U Voltage I Current P CosPhi T Temperature S Star-Delta</p> <p>Output</p> <p>1 1 changer 2 2 changers 3 1 NC contact / 1 NO contact</p>	<p>Special functions</p> <p>1 = Additional asymmetry monitoring</p> <p>Measuring circuit</p> <table border="0"> <tr> <td>A No measuring circuit</td> <td>I 12 Vdc</td> </tr> <tr> <td>B 3(N)~115/66 Vac</td> <td>J 24 Vdc</td> </tr> <tr> <td>C 3(N)~230/132 Vac</td> <td>K 36 Vdc</td> </tr> <tr> <td>D 3(N)~400/230 Vac</td> <td>L 48 Vdc</td> </tr> <tr> <td>E 1 ≅ 30/60/300 Vac/dc</td> <td>M 1~110 Vac</td> </tr> <tr> <td>F 1 ≅ 100mA/1A/10A ac/dc</td> <td>N 1~230 Vac</td> </tr> <tr> <td>G PTC</td> <td>O 1 A</td> </tr> <tr> <td>H CosPhi</td> <td>P 5 A</td> </tr> </table> <p>Connecting voltage</p> <p>1 Measuring circuit 2 24...240 Vac/dc 3 230 Vac</p>	A No measuring circuit	I 12 Vdc	B 3(N)~115/66 Vac	J 24 Vdc	C 3(N)~230/132 Vac	K 36 Vdc	D 3(N)~400/230 Vac	L 48 Vdc	E 1 ≅ 30/60/300 Vac/dc	M 1~110 Vac	F 1 ≅ 100mA/1A/10A ac/dc	N 1~230 Vac	G PTC	O 1 A	H CosPhi	P 5 A
A No measuring circuit	I 12 Vdc																
B 3(N)~115/66 Vac	J 24 Vdc																
C 3(N)~230/132 Vac	K 36 Vdc																
D 3(N)~400/230 Vac	L 48 Vdc																
E 1 ≅ 30/60/300 Vac/dc	M 1~110 Vac																
F 1 ≅ 100mA/1A/10A ac/dc	N 1~230 Vac																
G PTC	O 1 A																
H CosPhi	P 5 A																

Temperature monitoring relay

EMR DT22G

Function description

If the supply voltage U is applied (green LED illuminated) and the cumulative resistance of the PTC-circuit is less than $3.6\text{k}\Omega$ (standard temperature of the motor), the output relays switch into on-position. Pressing the test/reset key under this conditions forces the output relays to switch into off-position. They remain in this state as long as the test/reset key is pressed and thus the switching function can be checked in case of fault. The test function is not effective using an external reset key.

When the cumulative resistance of the PTC-circuit exceeds $3.6\text{k}\Omega$ (at least one of the PTCs has reached the cut-off temperature), the output relays switch into off-position (red LED illuminated).

The output relays again switch into on-position (red LED not illuminated), if the cumulative resistance drops below $1.8\text{k}\Omega$ by cooling down of the PTC and either a reset key (internal or external) was pressed or the supply voltage was disconnected and re-applied.

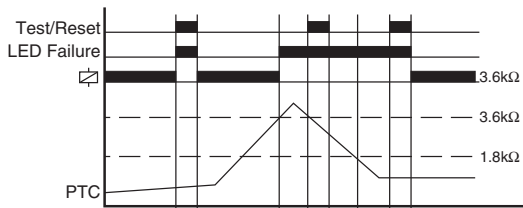
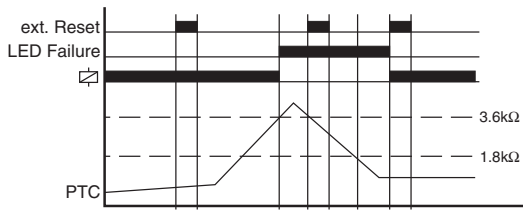

Connection

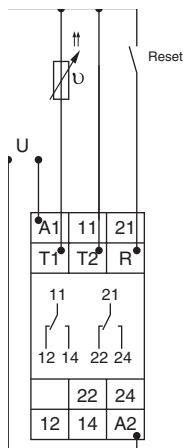

Dimensions

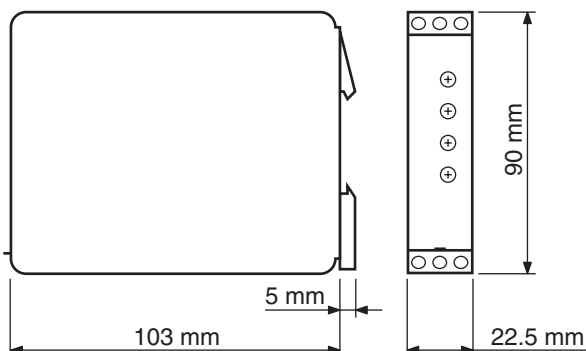

Load monitoring

EMR DP22H



EMR DP22H

- **Power factor monitoring ($\cos\phi$) in 1- or 3-phase mains**
- **Multifunction**
- **Error memory (LATCH)**
- **Recognition of disconnected consumers**
- **Suitable for VFI (10 to 100 Hz)**
- **2 changers**

Functions

Load monitoring ($\cos\phi$) in 1- or 3-phase mains with adjustable thresholds, timing for start-up suppression and tripping delay separately adjustable and the following functions selectable by means of rotary switch.

OVER	Overload monitoring
OVER+LATCH	Overload monitoring with error memory
UNDER	Underload monitoring
UNDER+LATCH	Underload monitoring with error memory
WIN	Monitoring the window between Min and Max
WIN+LATCH	Monitoring the window between Min and Max with error memory

Time ranges

Start-up suppression time: Adjustment range 1 ... 100 s

Tripping delay: Adjustment range 0.1 ... 40 s

Indicators

Green LED ON:	indication of supply voltage
Green LED flashing:	indication of start-up suppression time
Yellow LED R ON/OFF:	indication of relay output
Yellow LED I=0 ON/OFF:	indication of disconnected consumers
Red LED ON/OFF:	indication of failure of the corresponding threshold
Red LED flashing:	indication of tripping delay of the corresponding threshold

Output relay

2 potential free change-over contacts

Rated voltage: 250 Vac

Switching capacity (distance <5 mm): 750 VA (3 A / 250 Vac)

Switching capacity (distance >5 mm): 1250 VA (5 A / 250 Vac)

Fusing: 5A fast acting

Connecting voltages

24 ... 240 Vac/dc, Terminals A1-A2 (galvanically separated)

Tolerance: 24 ... 240 Vdc, -20% ... +25% (galvanically separated)

24 ... 240 Vac, -15% ... +10% (galvanically separated)

100% duration of operation

Reference data

Selectron® EMR	Article no.
----------------	-------------

DP22H 24 ... 240 Vac/dc	41230008
-------------------------	----------

(Order data see chapter 1)

Load monitoring

EMR DP22H

Technical data	
Nominal consumption	4.5 VA / 1 W
Nominal frequency	48 ... 400 Hz (24 ... 240 Vac)
	16 ... 48 Hz (48 ... 240 Vac)
Ripple at dc	10%
Drop-out voltage	>15% of the supply voltage
Base accuracy	±5° (equivalent to 5% at $\cos \varphi = 0.8$)
Repetition accuracy	±1.8° (equivalent to 1.8% at $\cos \varphi = 0.8$)
Adjustment accuracy	≤5% (at $\cos \varphi = 0.8$)
Temperature influence	≤0.1% / °C
Recovery time	500 ms
Measuring circuit:	
Measured variable	ac sine (10 ... 100 Hz)
Measuring-input voltage:	
1-phase mains	40 ... 415 Vac (300 V gegen Erde), terminals L1i-L2/L3
3-phase mains	3~ 23/40 bis 240/415 V, terminals L1i-L2-L3
Overload capacity:	
1-phase mains	500 V
3-phase mains	3~ 289/500 V
Input resistance	>1 MΩ
Measuring-input current	0.5 ... 10 A, terminals L1i-L1k (for I>8 A distance >5 mm)
Overload capacity	12 A permanently
Input resistance	5 mΩ
Switching threshold $\cos \varphi$	
Max.	0.2 ... 1.0
Min.	0.1 ... 0.99

Type key

EMR D P 2 2 H ...	
Construction	Special functions
D Industrial design 22.5 mm	1 = Additional asymmetry monitoring
S pluggable 11 poles	
Function	Measuring circuit
U Voltage	A No measuring circuit
I Current	B 3(N)~115/66 Vac
P CosPhi	C 3(N)~230/132 Vac
T Temperature	D 3(N)~400/230 Vac
S Star-Delta	E 1 ≅ 30/60/300 Vac/dc
	F 1 ≅ 100mA/1A/10A ac/dc
	G PTC
	H CosPhi
Output	Connecting voltage
1 1 changer	1 Measuring circuit
2 2 changers	2 24...240 Vac/dc
3 1 NC contact / 1 NO contact	3 230 Vac
	I 12 Vdc
	J 24 Vdc
	K 36 Vdc
	L 48 Vdc
	M 1~110 Vac
	N 1~230 Vac
	O 1 A
	P 5 A

Load monitoring

EMR DP22H

Function description

When the supply voltage U is applied, the output relays switch into on-position (yellow LED R and LED I=0 illuminated) and the set interval of the start-up suppression (START) begins (green LED U flashes). Changes of the measured power factor ($\cos\phi$) during this period do not affect the state of the output relay. After the interval has expired the green LED is illuminated steadily.

For all the functions the LEDs MIN and MAX are flashing alternating, when the minimum value for the measured power factor was chosen to be greater than the maximum value.

Overload monitoring (OVER, OVER+LATCH)

When the measured power factor exceeds the value adjusted at the MAX-regulator, the set interval of the tripping delay (DELAY) begins (red LED MAX flashes). After the interval has expired (red LED MAX illuminated), the output relays switch into off-position (yellow LED R not illuminated). The output relays again switch into on-position (yellow LED R illuminated), when the measured power factor falls below the value adjusted at the MIN-regulator (red LED MAX not illuminated).

If the error memory is activated (OVER+LATCH) and the measured power factor remains above the MAX-value longer than the set interval of the tripping delay, the output relays remain in the off-position even if the measured power factor falls below the value adjusted at the MIN-regulator. After resetting the failure (interrupting and re-applying the supply voltage), the output relays switch into on-position and a new measuring cycle begins with the set interval of the start-up suppression (START).

Underload monitoring (UNDER, UNDER+LATCH)

When the measured power factor falls below the value adjusted at the MIN-regulator, the set interval of the tripping delay (DELAY) begins (red LED MIN flashes). After the interval has expired (red LED MIN illuminated), the output relays switch into off-position (yellow LED R not illuminated). The output relays again switch into on-position (yellow LED R illuminated), when the measured power factor exceeds the value adjusted at the MAX-regulator.

If the error memory is activated (UNDER+LATCH) and the measured power factor remains below the MIN-value longer than the set interval of the tripping delay, the output relays remain in the off-position even if the measured power factor exceeds the value adjusted at the MAX-regulator. After resetting the failure (interrupting and re-applying the supply voltage), the output relays switch into on-position and a new measuring cycle begins with the set interval of the start-up suppression (START).

Window function (WIN, WIN+LATCH)

The output relays switch into on-position (yellow LED R illuminated) when the measured power factor exceeds the value adjusted at the MIN-regulator. When the measured power factor exceeds the value adjusted at the MAX-regulator, the set interval of the tripping delay (DELAY) begins (red LED MAX flashes). After the interval has expired (red LED MAX illuminated), the output relays switch into off-position (yellow LED R not illuminated). The output relays again switch into on-position (yellow LED R illuminated) when the measured power factor falls below the value adjusted at the MAX-regulator (red LED

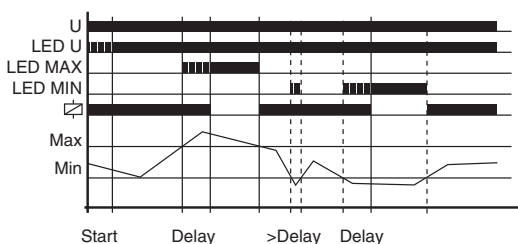
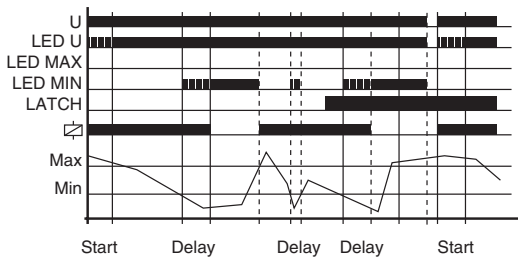
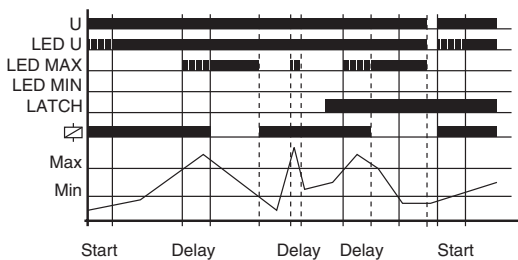

Load monitoring

EMR DP22H

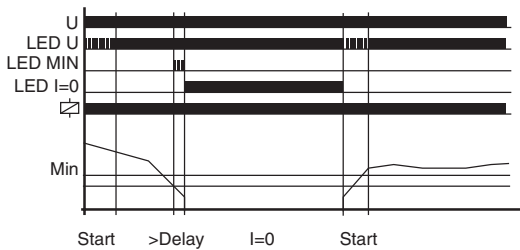
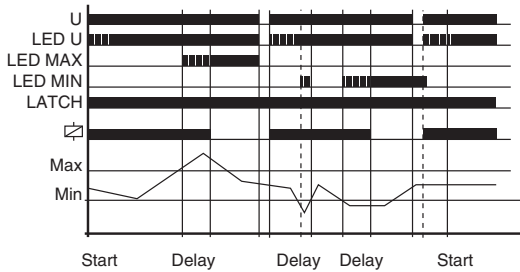

MAX not illuminated). When the measured power factor falls below the value adjusted at the MIN-regulator, the set interval of the tripping delay (DELAY) begins again (red LED MIN flashes). After the interval has expired (red LED MIN illuminated), the output relays switch into off-position (yellow LED R not illuminated).

If the error memory is activated (WIN+LATCH) and the measured power factor remains below the MIN-value longer than the set interval of the tripping delay, the output relays remain in the off-position even if the measured power factor exceeds the value adjusted at the MIN-regulator. If the measured power factor remains above the MAX-value longer than the set interval of the tripping delay, the output relays remain in the off-position even if the measured power factor falls below the value adjusted at the MAX-regulator. After resetting the failure (interrupting and re-applying the supply voltage), the output relays switch into on-position and a new measuring cycle begins with the set interval of the start-up suppression (START).

Recognition of disconnected consumers

When the current flow between L1i and L1k is interrupted for a time that is shorter than the minimum (< 100 ms) or set triggering delay, it is assumed that the consumer has been switched off deliberately and that no fault is present (yellow LED I=0 illuminated), output relays remain picked up (yellow LED R illuminated).

When the current flow is restored (consumer is switched back on), the measuring cycle is restarted with the set interval of the start-up suppression (START).

Connection

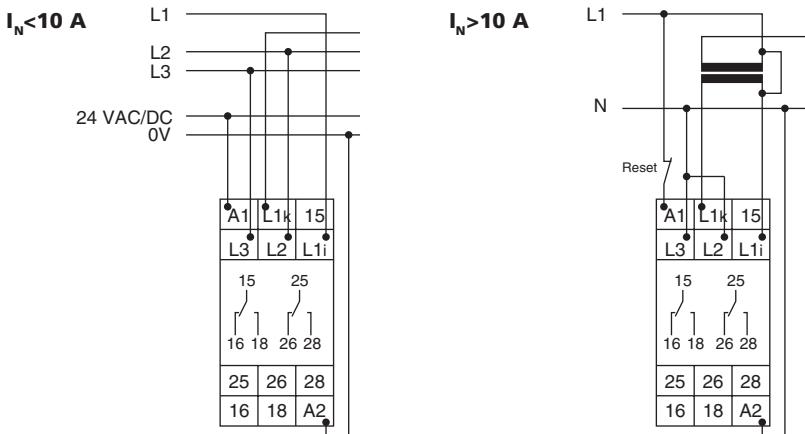

Dimensions

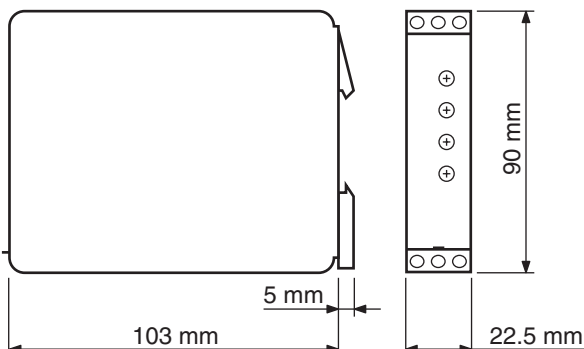

Accessories

Protection cover

Protection cover of self-extinguishing plastic material with spring catch to seal with lead for all devices of the EMR series for protection of inadvertent or unauthorized changes of setup parameters.

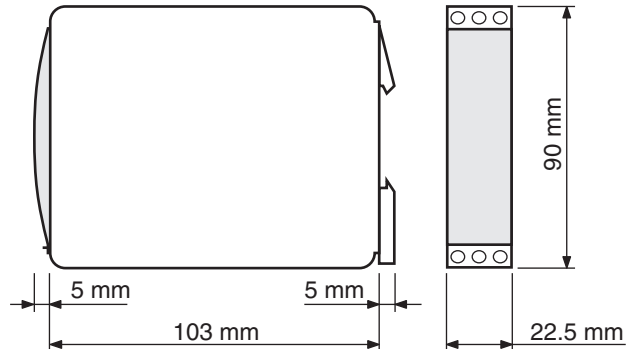
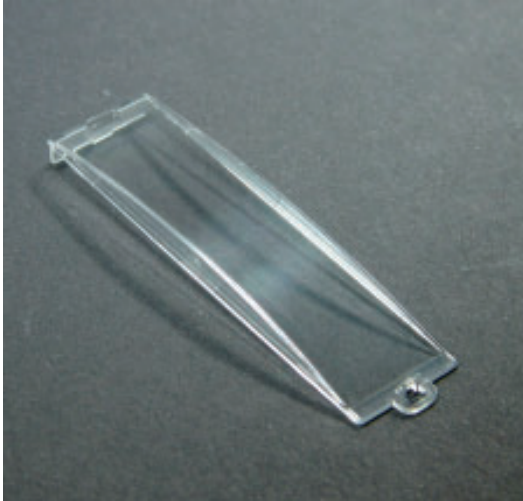

Description	Type	Weight	Article no
Protection cover for EMR (Order data see chapter 1)	SA 1	5 g	41230102

Mounting plate

The mounting-plate is used for the attachment of a DIN rail device on a mounting plate. Attachment by means of screws with 4 mm diameter.

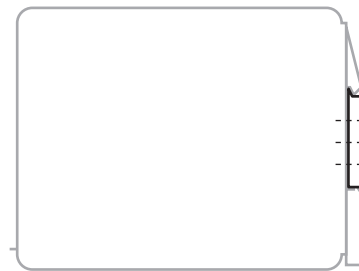

Description	Type	Weight	Article no
Mounting plate for EMR (Order data see chapter 1)	MP-1	5 g	41230101

Technical safety advice

This manual contains the information necessary for the correct utilisation of the products described therein. It is intended for technically qualified persons who are involved as either

- planning engineers familiar with the safety concepts of automation technology;
- or, operating personnel, who have been instructed in handling automation equipment and have a knowledge of the contents of this manual concerning operation;
- or, installation and servicing personnel possessing the necessary training to repair such an automation system or who have the authority to put such circuits and equipment/systems into operation, to earth or label them according to the relevant safety standards.

The products are constructed, manufactured and tested in compliance with the relevant VDE standards, VDE specifications and IEC recommendations.

Danger warning

These warnings serve both as a guide for those persons involved in a project and as safety advice to prevent damage to the products themselves or to associated equipment.

Due to advancements in technology, the wiring diagram on the actual device may be different than shown in this catalogue. In all instances where the actual device diagram is different, the wiring diagram on the device must be used when electrical connections are made.

Correct utilisation, configuration and assembly

The equipment is to be used only for the applications stated in the catalogue and technical literature, and only in conjunction with auxiliary equipment and devices that are recommended or approved by Selectron Systems Ltd.

Further, it should be noted that:

- the automation equipment must be disconnected from any power supply before it is assembled, disassembled or the configuration modified.
- Solid state electronic switches must not be tested with incandescent lamps or connected to a load that exceeds its rating.
- trouble-free and safe operation of the

products requires correct transportation as well as appropriate storage, assembly and wiring.

- the systems may only be installed by trained personnel. In doing so, the relevant requirements contained in VDE 0100, VDE 0113, IEC 364, etc. must be complied with.

Prevention of material damage or personal injury

Additional external safety devices or facilities must be provided wherever significant material damage or even personal injury could result from a fault occurring in an automation system. A defined operating status must be ensured or forced by such devices or facilities (e.g. by independent limit switches, mechanical interlocks, etc.).

Advice concerning planning and installation of the products

- The safety and accident prevention measures applicable to a specific application are to be observed.
- In the case of mains-operated equipment, a check is to be made before putting it into operation to ensure that the preset mains voltage range is suitable for the local supply.
- In the case of a 24 V supply, care must be taken to ensure sufficient electrical insulation of the secondary side. Use only mains power supply units that conform to IEC 364-4-41 or HD 384.04.41 (VDE 0100 Part 410).
- Automation systems and their operating elements are to be installed in such a way that they are sufficiently protected against accidental operation.

Warranty

Selectron Systems Ltd. warrants its products to be free from defects in material and workmanship for a period of one year from the date of shipment. All claims under this warranty must be made within thirty (30) days of the discovery of the defect, and all defective products must be returned at the buyer's expense. Buyer's sole and exclusive right will be limited to, at the option of Selectron Systems Ltd., the repair or replacement by Selectron Systems Ltd., of any defective products for which a claim is made.

In all other matters please refer to the "General terms of business" concerning Selectron Systems Ltd.

Note

The information given in this documentation corresponds to the state of development at the time of going to press and is therefore not binding. Selectron Systems Ltd. reserves the right to make alterations in the interests of technical advancement or product improvement at any time without giving reasons for doing so.

Prescriptions and standards

Mechanical data	
Housings in self-extinguishing plastic material. Protection mode IP 40	
Mounting: snapping mode:	Fixing on profile rail according DIN 46277/3 (EN 50 022)
Connection	via contact protected terminals up to 4 mm ² , protecting mode IP 20
Environmental conditions	
Admissible environmental temperatures from -25 °C ... +55 °C (corresponds IEC 68-1)	
Storage and transport temperature from -25 °C ... +70 °C	
Application class	IEC 721-3-3 (EN 60721-3-3)
Output relay	
Electrical lifetime:	230 Vac, min. 2x10 ⁵ switching cycles at 1000 VA ohmic load.
Mechanical lifetime:	min. 20 x 10 ⁶ switching cycles
Contact material	AgNi
Frequency range	48 ... 400 Hz / 24 ... 240 Vac, 16 ... 48 Hz / 24 ... 48 Vac
Duration of operation	100%
Protection	
Protection of the unit	5 A fast
Terminals	
Contact protection according VDE 0106 and VBG 4	
Terminal type:	sleeve with indirect screw pressure
Wire to connect:	rigid or flexible
Connecting limit:	4 mm ²
Terminal variants:	1 wire 0,5 mm ² ... 2,5 mm ² with/without wire end covers
1 wire 4 mm ² without wire end covers	
2 wires 0,5 mm ² ... 1,5 mm ² with/without wire end covers	
2 wires 2,5 mm ² flexible without wire end covers	
max. screw in torque:	1,0 Nm
Terminal screw for screw driver with PZ-1	
Insulation	
Isolation nominal voltage:	250 Vac (corresponds to IEC 60664-1)
Rating surge voltage:	4 kV, over-voltage category III, corresponds to IEC 60664-1
Electromagnetic compatibility	
Electrostatic discharge: Level 3, 6 kV contact, 8 kV air (corresponds to IEC 1000-4-2)	
High frequency electromagnetic fields: Level 3, 10 V/m (corresponds to IEC 1000-4-3)	
Fast transients: Level 4, 4 kV / 2,5 kHz, 5/50 ns (corresponds to IEC 1000-4-4)	
Lightning discharge: Level 3, 2 kV com., 1 kV dif., (corresponds to IEC 1000-4-5)	
Cable running disturbances inducted by HF fields: Level 3, 10 V RMS (corresponds to IEC 1000-4-6)	
Spurious radiation net and aerial network: Class B (corresponds to CISPR 22)	
Prescriptions	
Air and leakage paces:	VDE 0110iGr. C/250
Test voltage:	VDE 0435 2000Vac
Low voltage directions according to IEC 664-1	
EMC emissions:	EN 50 081-1 and EN 55 022 class B
EMC interference stability:	Voltage impact strength according to IEC 1000-4-5
Burst:	EN 50 082-2, EN 61 812-1 (level 3)
ESD:	IEC 1000-4-2
HF over metallic circuits:	EN 50 082-2, ENPr 50141
Electro magnetic HF field according to EN 50 082-2, ENPr 50140 and ENPr 50204	
Production standard:	according to ISO 9001