

Content

Monitoring relay pluggable

1-phase current monitoring relay	5.2
1-phase direct-current voltage monitoring relay	5.6
1-phase voltage monitoring relay	5.10
3-phase voltage monitoring relay	5.14
3-phase voltage monitoring relay (Multifunction)	5.18
Accessories monitoring relays	5.22
Technical safety advice	5.23
Prescriptions and standards	5.24

1-phase current monitoring relay

EMR SI230, SI23P



EMR SI230

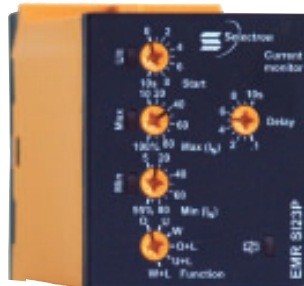

EMR SI23P

- ac current monitoring in 1-phase mains
- Measuring range 1A / 5A ac
- Multifunction
- Error Memory (Latch)
- 2 change-over contacts

Functions

ac current monitoring in 1-phase mains with adjustable thresholds, timing for start-up suppression and tripping delay separately adjustable and the following functions (selectable by means of rotary switch)

- Overcurrent monitoring
- Overcurrent monitoring with error memory
- Undercurrent monitoring
- Undercurrent monitoring with error memory
- Monitoring the window between Min and Max
- Monitoring the window between Min and Max with error memory

Time ranges

Start-up suppression time: Adjustment range 0 ... 10 s
Tripping delay: Adjustment range 0.1 ... 10 s

Indicators

Green LED ON: indication of supply voltage
Green LED flashing: indication of start-up suppression time
Yellow LED ON/OFF: indication of relay output
Red LED ON/OFF: indication of failure of the corresponding threshold
Red LED flashing: indication of tripping delay of the corresponding threshold

Output relay

2 potential free change-over contacts
Rated voltage: 250 Vac
Switching capacity: 1250 VA (5 A / 250 Vac)
Fusing: 5A fast acting

Connecting voltages

230 Vac, -15% ... +10% (galvanically separated)
100% duration of operation

Reference data

Selectron® EMR	Article no.
EMR SI230 1A	41230015
EMR SI23 P 5A	41230016
(Order data see chapter 1)	

1-phase current monitoring relay

EMR SI230, SI23P

Technical data	
Nominal consumption	8 VA / 1 W
Nominal frequency	48 ... 63 Hz
Wave form ac	sine
Drop-out voltage	>20% of the supply voltage
Base accuracy	±5% (of maximum nominal value)
Adjustment accuracy	≤5% (of maximum nominal value)
Repetition accuracy	≤2%
Temperature influence	≤0.1% / °C
Frequency response	-
Recovery time	500 ms
Measuring circuit: Input:	
1 A / 5 A ac	terminals 6 (21) and 7 (24)
Overload capacity:	
1 A ac	10 A
5 A ac	10 A
Input resistance:	
1 A ac	< 10 mΩ
5 A ac	< 10 mΩ
Switching threshold:	
Max:	10% ... 100% of I_N
Min:	5% ... 95% of I_N

Type key

EMR		S	I	2	3	O	...
Construction		Special functions					
D Industrial design 22.5 mm		1 = Additional asymmetry monitoring					
S pluggable 11 poles		Measuring circuit					
Function		A No measuring circuit					
U Voltage		B 3(N)~115/66 Vac					
I Current		C 3(N)~230/132 Vac					
P CosPhi		D 3(N)~400/230 Vac					
T Temperature		E 1≅30/60/300 Vac/dc					
S Star-Delta		F 1≅100mA/1A/10A ac/dc					
Output		G PTC					
1 1 changer		H CosPhi					
2 2 changers		I 12 Vdc					
3 1 NC contact / 1 NO contact		J 24 Vdc					
Connecting voltage		K 36 Vdc					
1 Measuring circuit		L 48 Vdc					
2 24...240 Vac/dc		M 1~110 Vac					
3 230 Vac		N 1~230 Vac					
		O 1 A					
		P 5 A					

1-phase current monitoring relay

EMR SI230, SI23P

Function description

When the supply voltage U is applied, the output relays switch into on-position (yellow LED illuminated) and the set interval of the start-up suppression (START) begins (green LED U flashes). Changes of the measured current during this period do not affect the state of the output relay. After the interval has expired the green LED is illuminated steadily.

For all the functions the LEDs MIN and MAX are flashing alternating, when the minimum value for the measured current was chosen to be greater than the maximum value.

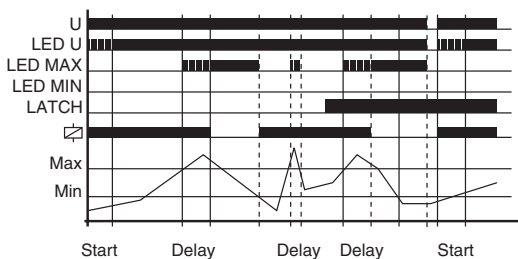

Overcurrent monitoring (OVER, OVER+LATCH)

When the measured current exceeds the value adjusted at the MAX-regulator, the set interval of the tripping delay (DELAY) begins (red LED MAX flashes). After the interval has expired (red LED MAX illuminated), the output relays switch into off-position (yellow LED not illuminated). The output relays again switch into on-position (yellow LED illuminated), when the measured current falls below the value adjusted at the MIN-regulator (red LED MAX not illuminated).

If the error memory is activated (OVER+LATCH) and the measured current remains above the MAX-value longer than the set interval of the tripping delay, the output relays remain in the off-position even if the measured current falls below the value adjusted at the MIN-regulator. After resetting the failure (interrupting and re-applying the supply voltage), the output relays switch into on-position and a new measuring cycle begins with the set interval of the start-up suppression (START).

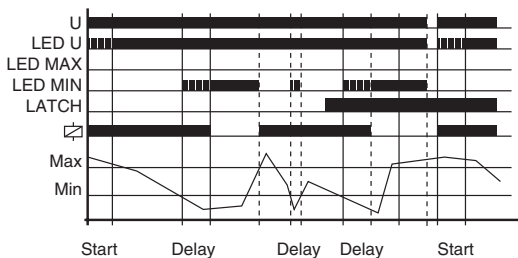

Undercurrent monitoring (UNDER, UNDER+LATCH)

When the measured current falls below the value adjusted at the MIN-regulator, the set interval of the tripping delay (DELAY) begins (red LED MIN flashes). After the interval has expired (red LED MIN illuminated), the output relays switch into off-position (yellow LED not illuminated). The output relays again switch into on-position (yellow LED illuminated), when the measured current exceeds the value adjusted at the MAX-regulator.

If the error memory is activated (UNDER+LATCH) and the measured current remains below the MIN-value longer than the set interval of the tripping delay, the output relays remain in the off-position even if the measured current exceeds the value adjusted at the MAX-regulator. After resetting the failure (interrupting and re-applying the supply voltage), the output relays switch into on-position and a new measuring cycle begins with the set interval of the start-up suppression (START).

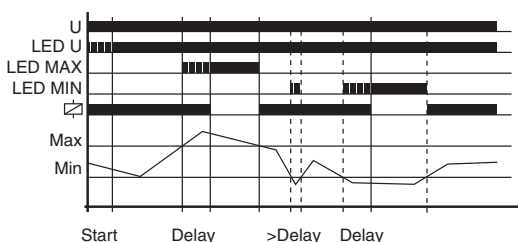

Window function (WIN, WIN+LATCH)

The output relays switch into on-position (yellow LED illuminated) when the measured current exceeds the value adjusted at the MIN-regulator. When the measured current exceeds the value adjusted at the MAX-regulator, the set interval of the tripping delay (DELAY) begins (red LED MAX flashes). After the interval has expired (red LED MAX illuminated), the output relays switch into off-position (yellow LED not illuminated). The output relays again switch into on-position (yellow LED illuminated) when the measured current falls below the value adjusted at the MAX-regulator (red LED MAX not illuminated). When the measured current falls below the value

1-phase current monitoring relay

EMR SI230, SI23P

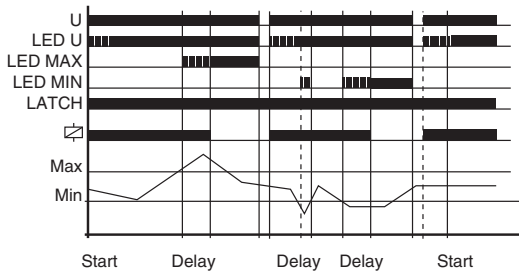

adjusted at the MIN-regulator, the set interval of the tripping delay (DELAY) begins again (red LED MIN flashes). After the interval has expired (red LED MIN illuminated), the output relays switch into off-position (yellow LED not illuminated).

If the error memory is activated (WIN+LATCH) and the measured current remains below the MIN-value longer than the set interval of the tripping delay, the output relays remain in the off-position even if the measured current exceeds the value adjusted at the MIN-regulator. If the measured current remains above the MAX-value longer than the set interval of the tripping delay, the output relays remain in the off-position even if the measured current falls below the value adjusted at the MAX-regulator. After resetting the failure (interrupting and re-applying the supply voltage), the output relays switch into on-position and a new measuring cycle begins with the set interval of the start-up suppression (START).

Connection

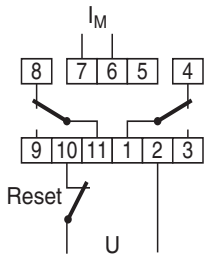

With error memory
Measuring range 11 A or 5 A
U = supply voltage 230 Vac

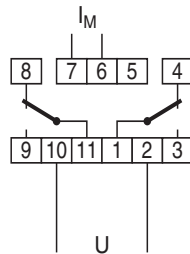

Without error memory
Measuring range 1 A or 5 A
U = supply voltage 230 Vac

Dimensions

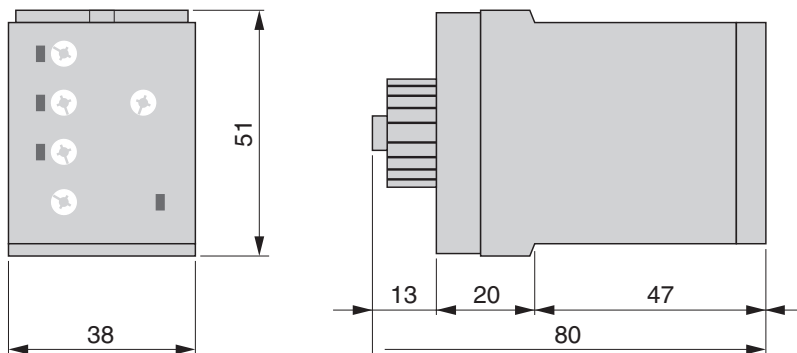

1-phase direct-current voltage monitoring relay

EMR SU21I, SU21J, SU21K, SU21L



EMR SU21I

- dc voltage monitoring in 1-phase mains
- Measuring range 12/24/36/48 Vdc
- Multifunction
- 2 change-over contacts

Functions

dc voltage monitoring in 1-phase mains with adjustable thresholds, and the following functions (selectable by means of rotary switch)

- Undervoltage monitoring
- Monitoring the window between Min and Max



EMR SU21J

Indicators

- Green LED ON: indication of supply voltage
- Yellow LED ON/OFF: indication of relay output
- Red LED ON/OFF: indication of failure of the corresponding threshold

Output relay

- 2 potential free change-over contacts
- Rated voltage: 250 Vac
- Switching capacity: 1250 VA (5 A / 250 Vac)
- Fusing: 5A fast acting



EMR SU21K

Connecting voltages

- 12/24/36/48 Vdc (= Measuring voltage)
- 100% duration of operation

Reference data

Selectron®	EMR	Article no.
SU21I	12 Vdc	41230009
SU21J	24 Vdc	41230010
SU21K	36 Vdc	41230011
SU21L	48 Vdc	41230012

(Order data see chapter 1)



EMR SU21L

1-phase direct-current voltage monitoring relay

EMR SU21I, SU21J, SU21K, SU21L

Technical data		
Nominal consumption		2 W
Ripple at dc		10%
Drop-out voltage		according to switching threshold
Base accuracy		±5% (of maximum nominal value)
Adjustment accuracy	±5% (of maximum nominal value)	
Repetition accuracy		≤2% (of maximum nominal value)
Temperature influence		<0.1% / °C
Recovery time		500 ms
Measuring circuit:	Measured variable	dc or ac sine (16.6 ... 400 Hz)
	Input:	
	12/24/36/48 Vdc	terminals 2 (A1) and 10 (A2)
	Overload capacity:	
	12/24/36/48 Vdc	-25% ... +30%
	Input resistance:	
	12/24/36/48 Vdc	according to nominal voltage 2 W
	Switching threshold:	
	Max:	80% ... 130% of U_N
	Min:	75% ... 125% of U_N

Type key

EMR S U 2 1 I ...	
Construction	Special functions
D Industrial design 22.5 mm	1 = Additional asymmetry monitoring
S pluggable 11 poles	
Function	Measuring circuit
U Voltage	A No measuring circuit
I Current	B 3(N)~115/66 Vac
P CosPhi	C 3(N)~230/132 Vac
T Temperature	D 3(N)~400/230 Vac
S Star-Delta	E 1≅30/60/300 Vac/dc
	F 1≅100mA/1A/10A ac/dc
	G PTC
	H CosPhi
Output	Connecting voltage
1 1 changer	1 Measuring circuit
2 2 changers	2 24...240 Vac/dc
3 1 NC contact / 1 NO contact	3 230 Vac
	I 12 Vdc
	J 24 Vdc
	K 36 Vdc
	L 48 Vdc
	M 1~110 Vac
	N 1~230 Vac
	O 1 A
	P 5 A

1-phase direct-current voltage monitoring relay

EMR SU21I, SU21J, SU21K, SU21L

Function description

For all the functions the LEDs MIN and MAX are flashing alternating, when the minimum value for the measured voltage was chosen to be greater than the maximum value.

If a failure already exists when the device is activated, the output relays remain in off-position and the LED for the corresponding threshold is illuminated.

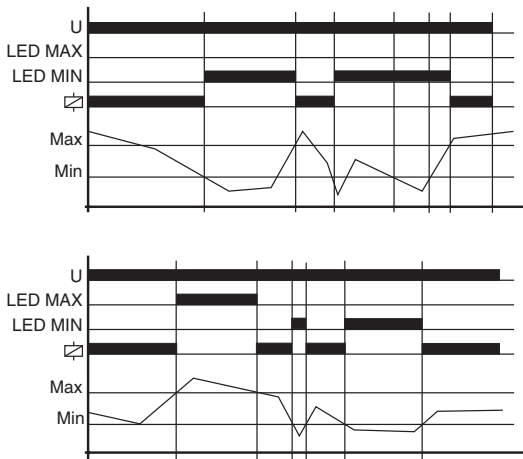

Under voltage monitoring (UNDER)

When the measured voltage falls below the value adjusted at the MIN-regulator, the output relays switch into off-position (yellow LED not illuminated). The output relays again switch into on-position (yellow LED illuminated), when the measured voltage exceeds the value adjusted at the MAX-regulator.

Window function (WIN)

The output relays switch into on-position (yellow LED illuminated) when the measured voltage exceeds the value adjusted at the MIN-regulator. When the measured voltage exceeds the value adjusted at the MAX-regulator, the output relays switch into off-position (yellow LED not illuminated). The output relays again switch into on-position (yellow LED illuminated) when the measured voltage falls below the value adjusted at the MAX-regulator (red LED MAX not illuminated). When the measured voltage falls below the value adjusted at the MIN-regulator, the output relays switch into off-position (yellow LED not illuminated).

Connection

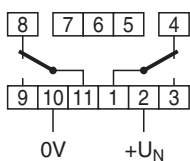

Measuring range 12, 24, 36 or 48 Vdc
Supply voltage = measuring range

Dimensions

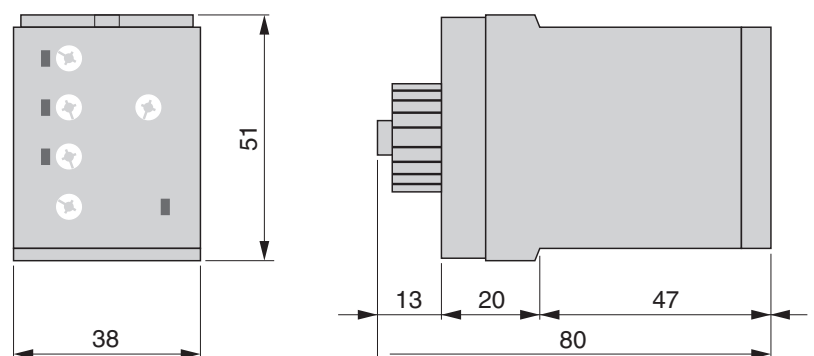

1-phase voltage monitoring relay

EMR SU21M, SU21N



EMR SU21M



EMR SU21N

- ac voltage monitoring in 1-phase mains
- Measuring range 110/230 Vac
- Multifunction
- 2 change-over contacts

Functions

ac voltage monitoring in 1-phase mains with adjustable thresholds, and the following functions (selectable by means of rotary switch)

- Undervoltage monitoring
- Monitoring the window between Min and Max

Indicators

- Green LED ON: indication of supply voltage
- Yellow LED ON/OFF: indication of relay output
- Red LED ON/OFF: indication of failure of the corresponding threshold

Output relay

- 2 potential free change-over contacts
- Rated voltage: 250 Vac
- Switching capacity: 1250 VA (5 A / 250 Vac)
- Fusing: 5A fast acting

Connecting voltages

- 110/230 Vac (= Measuring voltage)
- 100% duration of operation

Reference data

Selectron® EMR		Article no.
SU21M	110 Vac	41230013
SU21N	230 Vac	41230014
(Order data see chapter 1)		

1-phase voltage monitoring relay

EMR SU21M, SU21N

Technical data		
Nominal consumption		110 V, 4 VA (1 W)
		230 V, 8 VA (1 W)
Nominal frequency		48 ... 63 Hz
Drop-out voltage		according to switching threshold
Base accuracy		±5% (of maximum nominal value)
Adjustment accuracy ±5% (of maximum nominal value)		
Repetition accuracy		≤2% (of maximum nominal value)
Temperature influence		<0.1% / °C
Recovery time		500 ms
Measuring circuit:	Measured variable	ac sine (48 ... 63 Hz)
	Input:	
	110/230 Vac	terminals 2 (A1) and 10 (A2)
	Overload capacity:	
	110/230 Vac	-30% ... +20%
	Input resistance:	
	110 Vac	according to nominal voltage 4 VA / 1 W
	230 Vac	according to nominal voltage 8 VA / 1 W
	Switching threshold:	
	Max:	80% ... 120% of U_N
	Min:	70% ... 110% of U_N

Type key

EMR S U 2 1 M ...	
Construction	Special functions
D Industrial design 22.5 mm	1 = Additional asymmetry monitoring
S pluggable 11 poles	
Function	Measuring circuit
U Voltage	A No measuring circuit
I Current	B 3(N)~115/66 Vac
P CosPhi	C 3(N)~230/132 Vac
T Temperature	D 3(N)~400/230 Vac
S Star-Delta	E 1≅ 30/60/300 Vac/dc
	F 1≅ 100mA/1A/10A ac/dc
	G PTC
	H CosPhi
Output	Connecting voltage
1 1 changer	1 Measuring circuit
2 2 changers	2 24...240 Vac/dc
3 1 NC contact / 1 NO contact	3 230 Vac
	I 12 Vdc
	J 24 Vdc
	K 36 Vdc
	L 48 Vdc
	M 1~110 Vac
	N 1~230 Vac
	O 1 A
	P 5 A

1-phase voltage monitoring relay

EMR SU21M, SU21N

Function description

For all the functions the LEDs MIN and MAX are flashing alternating, when the minimum value for the measured voltage was chosen to be greater than the maximum value.

If a failure already exists when the device is activated, the output relays remain in off-position and the LED for the corresponding threshold is illuminated.

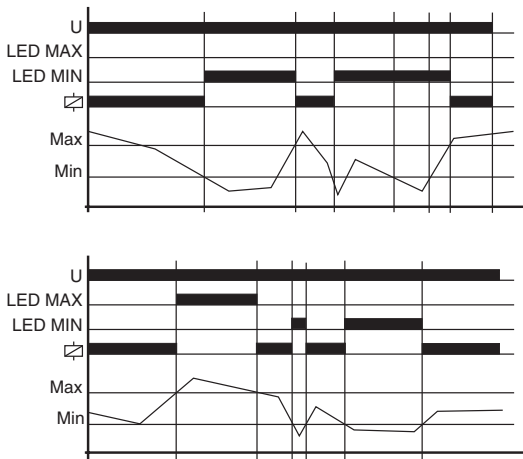

Under voltage monitoring (UNDER)

When the measured voltage falls below the value adjusted at the MIN-regulator, the output relays switch into off-position (yellow LED not illuminated). The output relays again switch into on-position (yellow LED illuminated), when the measured voltage exceeds the value adjusted at the MAX-regulator.

Window function (WIN)

The output relays switch into on-position (yellow LED illuminated) when the measured voltage exceeds the value adjusted at the MIN-regulator. When the measured voltage exceeds the value adjusted at the MAX-regulator, the output relays switch into off-position (yellow LED not illuminated). The output relays again switch into on-position (yellow LED illuminated) when the measured voltage falls below the value adjusted at the MAX-regulator (red LED MAX not illuminated). When the measured voltage falls below the value adjusted at the MIN-regulator, the output relays switch into off-position (yellow LED not illuminated).

Connection

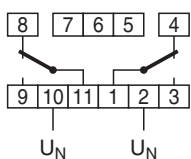

Measuring range 110 or 230 Vac
Supply voltage = measuring range

Dimensions

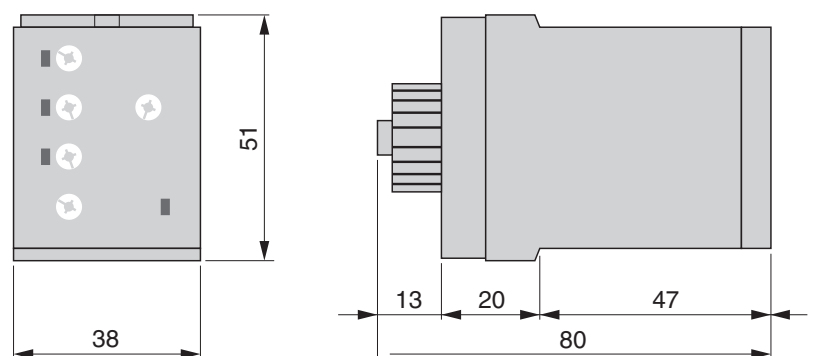

3-phase voltage monitoring relay

EMR SU31D



EMR SU31D

- Voltage monitoring in 3-phase mains
- Measuring range 400/230 Vac 3Ph
- Monitoring of phase sequence and phase failure
- Detection of reverse voltage
- Connection of neutral wire optional
- 1 NC contact / 1 NO contact

Functions

Monitoring of phase sequence, phase failure and detection of return voltage (by means of evaluating the asymmetry).

Indicators

Green LED ON: indication of supply voltage
Yellow LED ON/OFF: indication of relay output

Output relay

1 NC contact / 1 NO contact
Rated voltage: 250 Vac
Switching capacity: 1250 VA (5 A / 250 Vac)
Fusing: 5A fast acting

Connecting voltages

3(N) ~400/230 V, Terminals (N)-L1-L2-L3 (= supply voltage)
100% duration of operation

Reference data

Selectron® EMR	Article no.
SU31D 400/230 Vac 3Ph	41230019
(Order data see chapter 1)	

3-phase voltage monitoring relay

EMR DU31D

Technical data	
Nominal consumption	3(N) ~400/230 V, 9 VA / 2 W
Nominal frequency	48 ... 63 Hz
Drop-out voltage	>20% of the nominal voltage
Recovery time	500 ms
Measuring circuit: Input:	
	3(N) ~400/230 V terminals (N)-L1-L2-L3 (= supply voltage)
Overload capacity:	
	3(N) ~400/230 V -30% ... +30%
Input resistance:	
	3(N) ~400/230 V according to nominal voltage 9 VA / 2 W
Asymmetry:	fix circa 30%

Type key

EMR S U 3 1 D ...	
Construction	Special functions
D Industrial design 22.5 mm	1 = Additional asymmetry monitoring
S pluggable 11 poles	
Function	Measuring circuit
U Voltage	A No measuring circuit
I Current	B 3(N)~115/66 Vac
P CosPhi	C 3(N)~230/132 Vac
T Temperature	D 3(N)~400/230 Vac
S Star-Delta	E 1 ≅ 30/60/300 Vac/dc
	F 1 ≅ 100mA/1A/10A ac/dc
	G PTC
	H CosPhi
Output	Connecting voltage
1 1 changer	1 Measuring circuit
2 2 changers	2 24...240 Vac/dc
3 1 NC contact / 1 NO contact	3 230 Vac
	I 12 Vdc
	J 24 Vdc
	K 36 Vdc
	L 48 Vdc
	M 1~110 Vac
	N 1~230 Vac
	O 1 A
	P 5 A

3-phase voltage monitoring relay

EMR DU31D

Function description

Phase sequence monitoring

When all the phases are connected in the correct sequence and the measured asymmetry is less than the fixed value, the output relays switch into on-position (yellow LED illuminated). When the phase sequence changes, the output relays switch into off-position (yellow LED not illuminated).

Phase failure monitoring

When one of the three phases fails, the output relays switch into off-position (yellow LED not illuminated).

Detection of reverse voltage (by means of evaluation of asymmetry)

The output relays switch into off-position (yellow LED not illuminated) when the asymmetry between the phase voltages exceeds the fixed value of the asymmetry.

An asymmetry caused by the reverse voltage of a consumer (e.g. a motor which continues to run on two phases only) does not effect the disconnection.

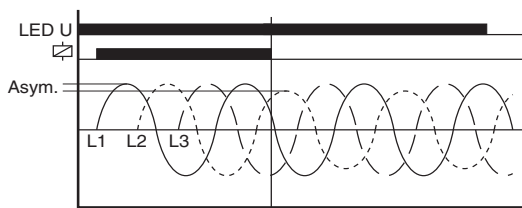
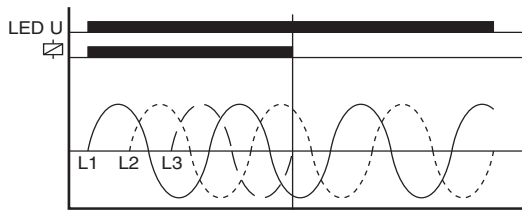
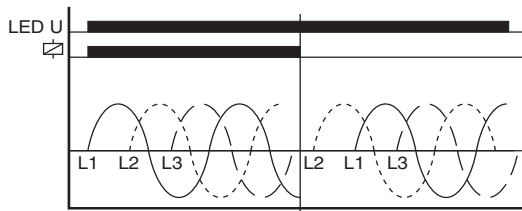

Connection

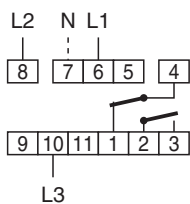

Measuring range 3 (N) 400/230 Vac
Supply voltage = measuring range

Dimensions

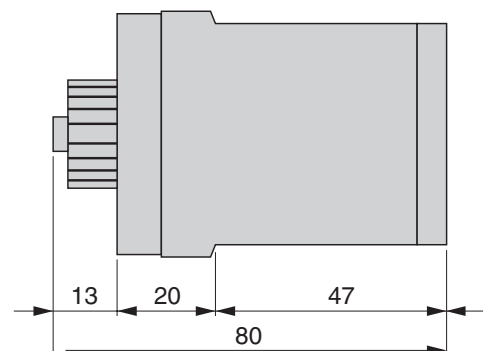
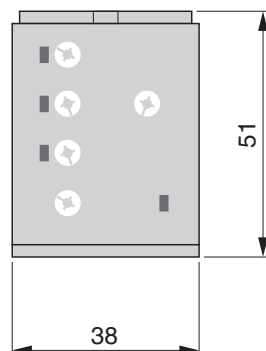

3-phase voltage monitoring relay (Multifunction)

EMR SU31C1, SU31D1



EMR SU31C1



EMR SU31D1

- Voltage monitoring in 3-phase mains
- Measuring range 230/132 / 400/230 Vac 3Ph
- Multifunction
- Monitoring of phase sequence and phase failure
- Additional asymmetry monitoring
- Connection of neutral wire optional
- 1 NC contact / 1 NO contact

Functions

Voltage monitoring in 3-phase mains with adjustable thresholds, adjustable tripping delay, monitoring of phase sequence and phase failure, monitoring of asymmetry with adjustable threshold and the following functions (selectable by means of rotary switch)

- Undervoltage monitoring
- Undervoltage monitoring and monitoring of phase sequence
- Monitoring of window between Min and Max
- Monitoring the window between Min and Max and monitoring of phase sequence.

Time ranges

Start-up suppression time: -

Tripping delay: Adjustment range 0.1 ... 10 s

Indicators

Red LED ON/OFF: indication of failure of the corresponding threshold

Red LED flashes: indication of tripping delay of the corresponding threshold

Yellow LED ON/OFF: indication of relay output

Output relay

1 NC contact / 1 NO contact

Rated voltage: 250 Vac

Switching capacity: 1250 VA (5 A / 250 Vac)

Fusing: 5A fast acting

Connecting voltages

3 (N) ~ 230/132 V, terminals (N)_L1_L2_L3 (= Measuring voltage)

3 (N) ~ 400/230 V, terminals (N)_L1_L2_L3 (= Measuring voltage)

100% duration of operation

Reference data

Selectron® EMR	Article no.
SU31D1 400/230 Vac 3Ph	41230018
SU31C1 230/132 Vac 3Ph	41230017

(Order data see chapter 1)

3-phase voltage monitoring relay (Multifunction)

EMR SU31C1, SU31D1

Technical data		
Nominal consumption	3(N) ~230/132 V, 6 VA (2 W)	
	3(N) ~400/230 V, 9 VA (2 W)	
Nominal frequency	48 ... 63 Hz	
Drop-out voltage	>20% of the nominal voltage	
Base accuracy	±5% (of maximum nominal value)	
Adjustment accuracy ±5% (of maximum nominal value)		
Repetition accuracy	≤2% (of maximum nominal value)	
Temperature influence	≤0.1% / °C	
Recovery time	500 ms	
Measuring circuit:	Measured variable	ac sine (48 ... 63 Hz)
	Input:	
	3(N) ~132/230 V	Terminals (N)-L1-L2-L3
	3(N) ~230/400 V	Terminals (N)-L1-L2-L3
	Overload capacity:	
	3(N) ~132/230 V	-30% ... +30%
	3(N) ~230/400 V	-30% ... +30%
	Input resistance:	
	3(N) ~132/230 V	according to nominal voltage 6 VA / 2 W
	3(N) ~230/400 V	according to nominal voltage 9 VA / 2 W
	Switching threshold:	
	Max:	80% ... 130% of U_N
	Min:	70% ... 120% of U_N
	Asymmetry:	5% ... 30%

Type key

EMR S U 3 1 C 1	
Construction	Special functions
D Industrial design 22.5 mm	1 = Additional asymmetry monitoring
S pluggable 11 poles	
Function	Measuring circuit
U Voltage	A No measuring circuit
I Current	B 3(N)~115/66 Vac
P CosPhi	C 3(N)~230/132 Vac
T Temperature	D 3(N)~400/230 Vac
S Star-Delta	E 1≅ 30/60/300 Vac/dc
	F 1≅ 100mA/1A/10A ac/dc
	G PTC
	H CosPhi
Output	Connecting voltage
1 1 changer	1 Measuring circuit
2 2 changers	2 24...240 Vac/dc
3 1 NC contact / 1 NO contact	3 230 Vac
	I 12 Vdc
	J 24 Vdc
	K 36 Vdc
	L 48 Vdc
	M 1~110 Vac
	N 1~230 Vac
	O 1 A
	P 5 A

3-phase voltage monitoring relay (Multifunction)

EMR SU31C1, SU31D1

Function description

For all the functions the LEDs MIN and MAX are flashing alternating, when the minimum value for the measured voltage was chosen to be greater than the maximum value.

If a failure already exists when the device is activated, the output relays remain in off-position and the LED for the corresponding threshold is illuminated.

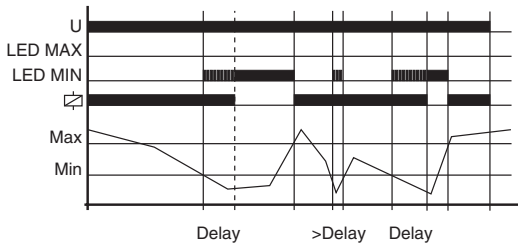

Under voltage monitoring (UNDER, UNDER+SEQ)

When the measured voltage (one of the phase voltages) falls below the value adjusted at the MIN-regulator, the set interval of the tripping delay (DELAY) begins (red LED MIN flashes). After the interval has expired (red LED MIN illuminated), the output relays switch into off-position (yellow LED not illuminated). The output relays again switch into on-position (yellow LED illuminated), when the measured voltage exceeds the value adjusted at the MAX-regulator.

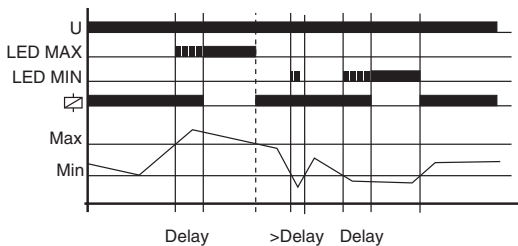

Window function (WIN, WIN+SEQ)

The output relays switch into on-position (yellow LED illuminated) when the measured voltage (one of the phase voltages) exceeds the value adjusted at the MIN-regulator. When the measured voltage exceeds the value adjusted at the MAX-regulator, the set interval of the tripping delay (DELAY) begins (red LED MAX flashes). After the interval has expired (red LED MAX illuminated), the output relays switch into off-position (yellow LED not illuminated). The output relays again switch into on-position (yellow LED illuminated) when the measured voltage falls below the value adjusted at the MAX-regulator (red LED MAX not illuminated). When the measured voltage falls below the value adjusted at the MIN-regulator, the set interval of the tripping delay (DELAY) begins again (red LED MIN flashes). After the interval has expired (red LED MIN illuminated), the output relays switch into off-position (yellow LED not illuminated).

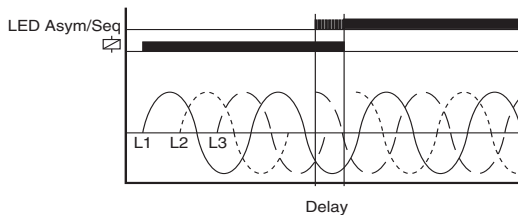

Phase sequence monitoring (SEQ)

Phase sequence monitoring is selectable for all functions.

If a change in phase sequence is detected (red LED Asym./SEQ flashes), the output relays switch into off-position after the interval has expired (yellow LED not illuminated, red LED Asym./SEQ illuminated).

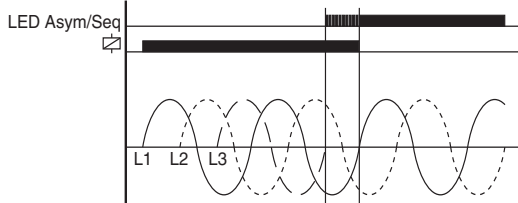

Phase failure monitoring (SEQ)

If one of the phase voltages fails, the set interval of the tripping delay (DELAY) begins (red LED SEQ flashes). After the interval has expired (red LED SEQ illuminated), the output relays switch into off-position (yellow LED not illuminated).

Reverse voltages of a consumer (e.g. a motor which continues to run on two phases only) do not effect the disconnection but can be monitored by using a proper value for the asymmetry.

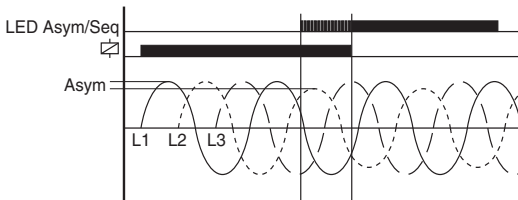

Asymmetry monitoring

If the asymmetry between the phases exceeds the value set at the ASYM-regulator, the set interval of the tripping delay (DELAY) begins (red LED ASYM flashes). After the interval has expired (red LED ASYM illuminated), the output relays switch into off-position (yellow LED not illuminated).

3-phase voltage monitoring relay (Multifunction)

EMR SU31C1, SU31D1

Shift of the star-point (asymmetry) through unequal phase-load with missing neutral wire

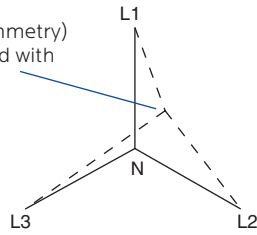

Loss of neutral wire by means of evaluation of asymmetry

A break of the neutral wire between power line and machinery is detected as soon as asymmetry between phase-to-phase voltage and neutral wire occurs. If the asymmetry exceeds the value set at the ASYM-regulator, the set interval of the tripping delay (DELAY) begins (red LED ASYM flashes). After the interval has expired (red LED ASYM illuminated), the output relays switch into off-position (yellow LED not illuminated). A break of the neutral wire between our device and the machinery can not be detected.

Connection

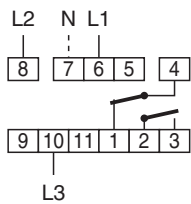

Measuring range 3 (N) 400/230 Vac
Supply voltage = measuring range

Dimensions

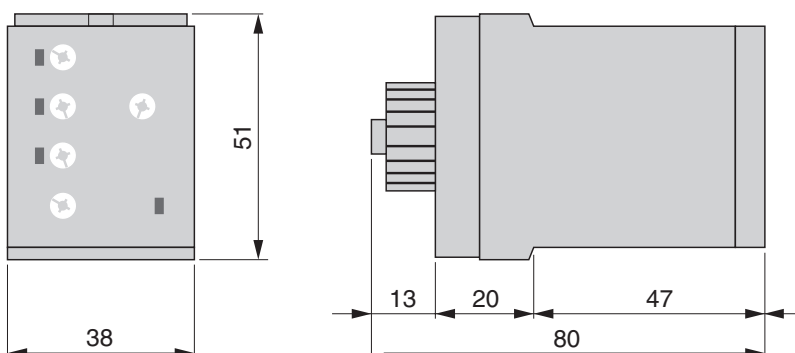

Accessories monitoring relays

Plug in socket

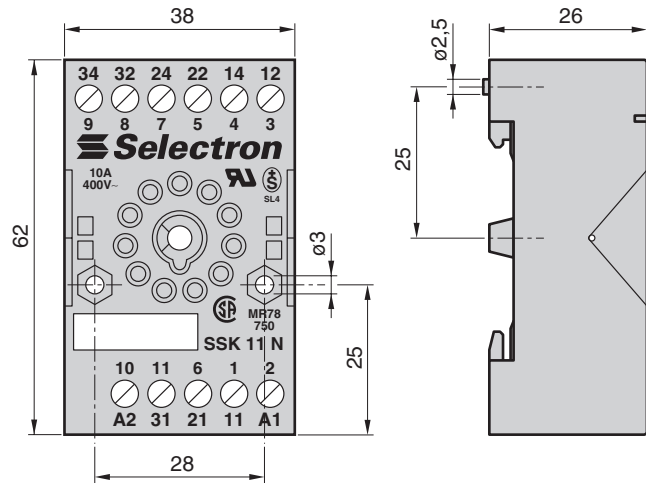

Description	Type	Article no.
Plug-in socket 11 poles	SSK 11 N	41910006
(Order data see chapter 1)		

Technical safety advice

This manual contains the information necessary for the correct utilisation of the products described therein. It is intended for technically qualified persons who are involved as either

- planning engineers familiar with the safety concepts of automation technology;
- or, operating personnel, who have been instructed in handling automation equipment and have a knowledge of the contents of this manual concerning operation;
- or, installation and servicing personnel possessing the necessary training to repair such an automation system or who have the authority to put such circuits and equipment/systems into operation, to earth or label them according to the relevant safety standards.

The products are constructed, manufactured and tested in compliance with the relevant VDE standards, VDE specifications and IEC recommendations.

Danger warning

These warnings serve both as a guide for those persons involved in a project and as safety advice to prevent damage to the products themselves or to associated equipment.

Due to advancements in technology, the wiring diagram on the actual device may be different than shown in this catalogue. In all instances where the actual device diagram is different, the wiring diagram on the device must be used when electrical connections are made.

Correct utilisation, configuration and assembly

The equipment is to be used only for the applications stated in the catalogue and technical literature, and only in conjunction with auxiliary equipment and devices that are recommended or approved by Selectron Systems Ltd.

Further, it should be noted that:

- the automation equipment must be disconnected from any power supply before it is assembled, disassembled or the configuration modified.
- Solid state electronic switches must not be tested with incandescent lamps or connected to a load that exceeds its rating.
- trouble-free and safe operation of the

products requires correct transportation as well as appropriate storage, assembly and wiring.

- the systems may only be installed by trained personnel. In doing so, the relevant requirements contained in VDE 0100, VDE 0113, IEC 364, etc. must be complied with.

Prevention of material damage or personal injury

Additional external safety devices or facilities must be provided wherever significant material damage or even personal injury could result from a fault occurring in an automation system. A defined operating status must be ensured or forced by such devices or facilities (e.g. by independent limit switches, mechanical interlocks, etc.).

Advice concerning planning and installation of the products

- The safety and accident prevention measures applicable to a specific application are to be observed.
- In the case of mains-operated equipment, a check is to be made before putting it into operation to ensure that the preset mains voltage range is suitable for the local supply.
- In the case of a 24 V supply, care must be taken to ensure sufficient electrical insulation of the secondary side. Use only mains power supply units that conform to IEC 364-4-41 or HD 384.04.41 (VDE 0100 Part 410).
- Automation systems and their operating elements are to be installed in such a way that they are sufficiently protected against accidental operation.

Warranty

Selectron Systems Ltd. warrants its products to be free from defects in material and workmanship for a period of one year from the date of shipment. All claims under this warranty must be made within thirty (30) days of the discovery of the defect, and all defective products must be returned at the buyer's expense. Buyer's sole and exclusive right will be limited to, at the option of Selectron Systems Ltd., the repair or replacement by Selectron Systems Ltd., of any defective products for which a claim is made.

In all other matters please refer to the "General terms of business" concerning Selectron Systems Ltd.

Note

The information given in this documentation corresponds to the state of development at the time of going to press and is therefore not binding. Selectron Systems Ltd. reserves the right to make alterations in the interests of technical advancement or product improvement at any time without giving reasons for doing so.

Prescriptions and standards

Mechanical data	
Housings in self-extinguishing plastic material. Protection mode IP 40	
Mounting: pluggable:	on plug-in socket 11 poles
Environmental conditions	
Admissible environmental temperatures from -25 °C ... +55 °C (corresponds IEC 68-1)	
Storage and transport temperature from -25 °C ... +70 °C	
Application class	IEC 721-3-3 (EN 60721-3-3)
Output relay	
Electrical lifetime:	230 Vac, min. 2x10 ⁵ switching cycles at 1000 VA ohmic load.
Mechanical lifetime:	min. 20 x 10 ⁶ switching cycles
Contact material	AgNi
Frequency range	48 ... 400 Hz / 24 ... 240 Vac, 16 ... 48 Hz / 24 ... 48 Vac
Duration of operation	100%
Protection	
Protection of the unit	5 A fast
Terminals plug-in socket	
Contact protection according VDE 0106 and VBG 4	
Terminal type:	sleeve with indirect screw pressure
Wire to connect:	rigid or flexible
Connecting limit:	4 mm ²
Terminal variants:	1 wire 0,5 mm ² ... 2,5 mm ² with/without wire end covers
	1 wire 4 mm ² without wire end covers
	2 wires 0,5 mm ² ... 1,5 mm ² with/without wire end covers
	2 wires 2,5 mm ² flexible without wire end covers
max. screw in torque:	0,5 Nm
Terminal screw for screw driver with PZ-1	
Insulation	
Isolation nominal voltage:	250 Vac (corresponds to IEC 60664-1)
Rating surge voltage:	4 kV, over-voltage category III, corresponds to IEC 60664-1
Electromagnetic compatibility	
Electrostatic discharge: Level 3, 6 kV contact, 8 kV air (corresponds to IEC 1000-4-2), EN 61000-4-2	
High frequency electromagnetic fields: Level 3, 10 V/m (corresponds to IEC 1000-4-3), EN 61000-4-3	
Fast transients: Level 4, 4 kV / 2,5 kHz, 5/50 ns (corresponds to IEC 1000-4-4), EN 61000-4-4	
Lightning discharge: Level 3, 2 kV com., 1 kV dif., (corresponds to IEC 1000-4-5, EN 61000-4-5)	
Cable running disturbances inducted by HF fields: Level 3, 10 V RMS (corresponds to IEC 1000-4-6), EN 61000-4-6	
Spurious radiation net and aerial network: Class B (corresponds to CISPR 22), EN 55011	
Prescriptions	
Air and leakage paces:	VDE 0110iGr. C/250, EN 50178 / VDE 0106
Test voltage:	VDE 0435 2000Vac, EN 50178 / VDE 0106
Low voltage directions according to EN 50178	
EMC emissions:	EN 55011
EMC interference stability:	Voltage impact strength according to IEC 1000-4-5, EN 61000-4-5
Burst:	EN 61 812-1 (level 3), EN 61000-4-4
ESD:	IEC 1000-4-2, EN 61000-4-2
HF over metallic circuits:	EN 50 082-2, ENPr 50141, EN55011
Electro magnetic HF field according to EN 61000-4-3	
Production standard:	according to ISO 9001